

INTRODUCTION

© M. Ragheb

1/29/2016

OVERVIEW

Energy storage and transport or conveyance systems are instrumental at bridging the supply and demand gap in the development of sustainable future energy supplies for both renewable and conventional systems.

Many energy and environmental problems can be traced back to inadequate energy storage. Humans use storage methods with efficiencies in the range of 20 percent, wasting the remaining 80 percent of the available energy. Transportation vehicles using the internal combustion engine, in addition to being wasteful of energy, are also a source of pollution.

Energy sources such as wind, solar and nuclear are restricted by the lack of an effective storage system to keep the power flowing during down periods.

The conventional systems such as coal or nuclear enjoy high capacity factors. That advantage can be enhanced by storing the energy produced in periods of low demand and conveying it to the consumption centers at periods of high demand. For instance, nuclear and coal electricity can be stored in electric car batteries during the night for later use during the daylight hours.

On the other hand, for the renewable systems such as wind and solar, the disadvantage of intermittence or low capacity factor can be remedied and the capacity factor brought to the level of the conventional energy systems by judicious energy storage.

UTILITY GENERATORS

Utility power generation is divided into Centralized and Distributed power systems.

Centralized Utility Generation

In centralized utility generation the unit power usually exceeds 10 MW. Three types of utility generators are encountered:

1. Base load generation: such as coal and nuclear power plants,
2. Dispatchable power generation: includes gas turbines and Concentrated Solar Power (CSP). Dispatchability is defined as:

“The ability to dispatch power. Dispatchable power generation refers to sources of electricity that can be dispatched at the request of power grid operators; that is, it can be turned on or off upon demand.”

3. Intermittent power generation: includes wind power and solar Photo Voltaic (PV).

Distributed Electrical Generation

The unit capacity in this case lies in the range: 3 kW to 10 MW. This electricity is generated close to the consumers, which reduces the transmission losses and reduces the investment in the transmission infrastructure.

These are primarily stand-alone applications characterized by modularity, reliability and availability.

ENERGY STORAGE OPTIONS

Wind energy can be used to produce hydrogen over the periods when the wind blows, used in a pumped storage system, or used to compress air to later drive turbines at the periods of peak demand.

In solar power plants, storing solar thermal energy allows its usage during non-solar periods and to dispatch the generated electricity during peak demand hours. It is suggested that Thermal Energy Storage (TES) could raise solar thermal power plant annual capacity factors from 25 percent without thermal storage, to 70 percent with storage.

Other than thermal energy storage, mechanical energy can be converted to potential energy which can later be recovered. Such a system uses pumped storage of water to a high reservoir when solar, wind, coal or nuclear power are available, and recover the stored energy using a water turbine when the energy is needed. This approach adds two inefficiencies to the overall system: those of the pump and the turbine. Potential energy storage is practiced on a small scale in grandfather clocks, and on a large scale with wind generated electricity in Europe.

Electrical, as well as thermal energy can be used to electrolyze water into hydrogen and oxygen:



The hydrogen can be stored or conveyed to a distant location for later recovery of the energy in fuel cells.

Photo Chemical Decomposition (PCD) can be used where solar radiation would decompose a material such as nitrosyl chloride into two separable and storable components:

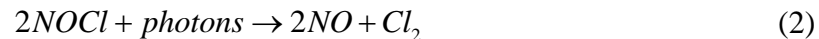

When recombined, energy is released.

A catalyst using a 2 percent addition of antimony (Sb) in gallium nitride (GaN) into the semiconductor GaN-Sb alloy which allows the Photo Chemical Decomposition of water into oxygen and hydrogen:



The reverse reaction can be carried out to recover the energy of the reaction. Storage in the system would be of the product materials in different containers.

ENERGY STORAGE EFFICIENCY

Electrical energy is stored in the form of chemical energy in electrical storage batteries such as lead-acid, nickel-iron and nickel-cadmium batteries or their equivalent. These include secondary or primary batteries or fuel cell storage systems. The efficiency of these systems ranges from 60 to 80 percent. The efficiency is here defined as:

$$\eta_{battery} = \frac{\text{Energy output [Watt.hr]}}{\text{Energy input [Watt.hr]}} \quad (4)$$

Other systems include storage as kinetic energy in flywheels, as magnetic energy in superconducting coils and in electric fields in capacitors.

ADVANTAGES OF ENERGY STORAGE

Energy storage in conjunction with renewable and conventional Energy systems provides the following advantages:

1. An increase in the operational stability,
2. It reduces intermittence (property of the source of energy),
3. It increases the plant's utilization and capacity factor (property of the energy plant),
4. It provides a "peak-shaving" ability and time-shifted operation.
5. It reduces the generation cost. This is true only if energy storage is cheaper than increasing the rated power of the production unit.

CHARACTERISTICS OF A VIABLE ENERGY STORAGE SYSTEM

A viable energy storage unit should possess the following basic characteristics [1]:

1. The energy storage unit should be capable of receiving energy at the maximum rate without excessive driving forces, such as the temperatures differences ΔT_i .
2. It should be capable of discharging energy at the maximum anticipated rate without excessive driving forces.
3. It should have small losses or a low self discharge characteristic.
4. It should be capable of a large number of charge-discharge cycles without a serious decrease in its capacity.
5. The unit must be inexpensive, not adding significantly to the cost of the basic energy production system.

EXAMPLE: THERMAL ENERGY STORAGE

A fraction of the thermal energy produced at a solar field can be stored, increasing the internal energy of the storage medium, such as a molten-salt, as:

1. Sensible heat,
2. Latent heat,
3. Thermochemical transformations.

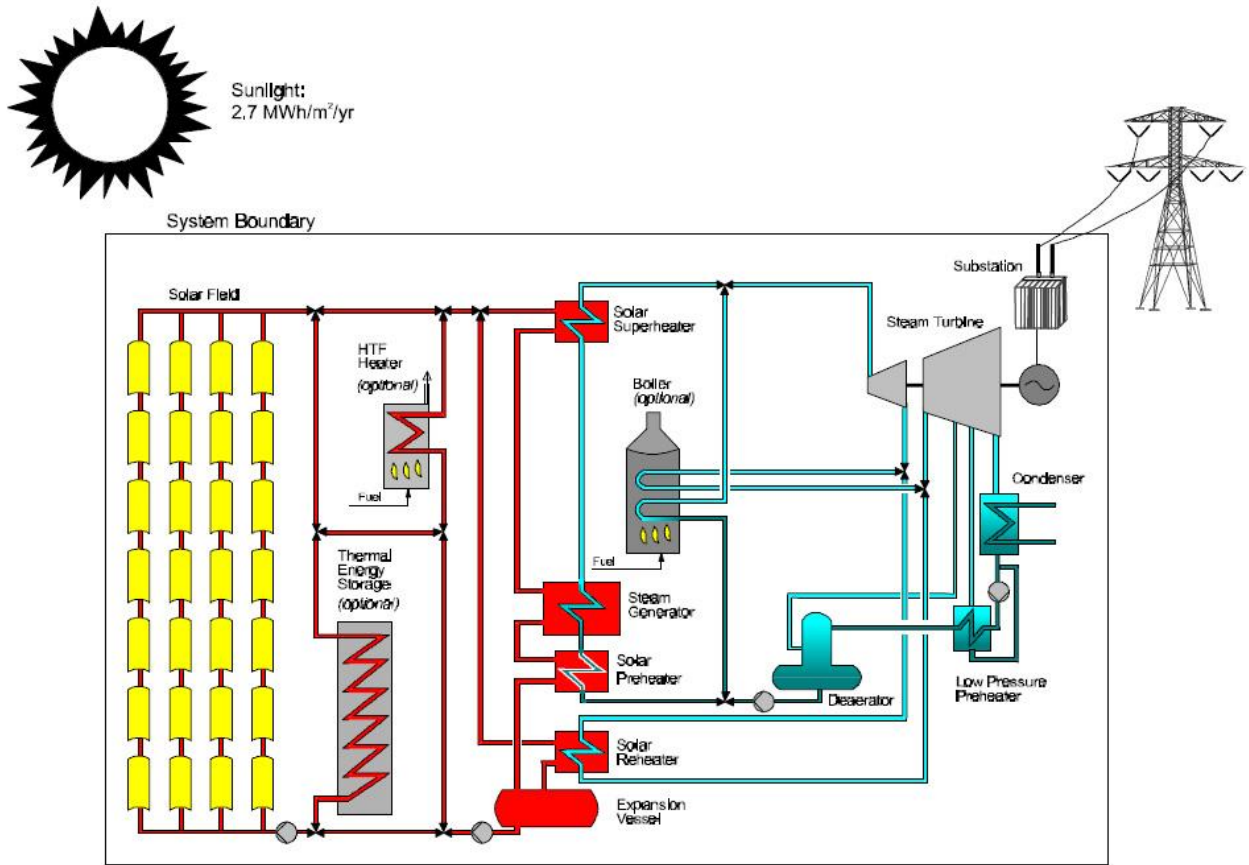

Figure 1. Energy Storage with Concentrated Solar Power (CSP) generation [2].

Concentrated Solar Power (CSP) possesses a unique feature in that it allows both energy storage and hybridization turning it from an intermittent to a dispatchable, stable and reliable form of energy generation.

Using energy storage, the thermal energy produced by the solar field is stored, thus “decoupling” the process of power generation from the intermittent solar source. Thermal cycling problems during startup and shut-down in a pure solar system are avoided.

Most existing solar plants are complemented with hybridization with an alternative fossil or renewable fuel such as wind, natural gas or coal.

TYPES OF THERMAL ENERGY STORAGE

One can classify the thermal storage systems according to their types or according to their usage.

In a classification according to type, they could be:

1. Direct systems: where the same substance is used a working medium and a storage medium. In this case, a Heat Exchanger (HX) system is not needed.
2. Indirect System: The working fluid and the storage medium are different. This requires the use of a heat exchanger.

According to utilization, thermal storage systems can be classified as:

1. Short term; providing operational stability,
2. Medium term; increasing the capacity factor and shifting the electrical generation hours.

Long term storage of energy is incompatible with electrical power generation.

TECHNICAL REQUIREMENTS FOR THERMAL ENERGY STORAGE MATERIALS

The following technical requirements must be met with a viable thermal storage material:

1. High energy density (per unit volume) and specific energy (per unit mass),
2. Good thermal conductivity,
3. Good heat transfer between the Heat Transfer Fluid (HTF) and the storage medium,
4. Mechanical and chemical stability,
5. Chemical compatibility between the Heat Transfer Fluid (HTF), heat exchanger and the storage medium,
6. Reversibility over a large number of charging/discharging cycles,
7. Low thermal losses,
8. Ease of process control.

Table 1. Thermal Storage present experience.

Project	Type	Storage medium	Cooling loop	Nominal temperature [°C]		Storage concept	Storage Tank volume [m ³]	Thermal capacity [MW _{hr}]
				Cold	Hot			
Irrigation Pump Coolidge, Arizona, USA	Parabolic Trough	Oil	Oil	200	228	One tank Thermocline	114	3
IEA-SSPS Almeria, Spain	Parabolic Trough	Oil	Oil	225	295	One tank Thermocline	200	5
SEGS I Daggett, California, USA	Parabolic Trough	Oil	Oil	240	307	Cold tank Hot tank	4160 4540	120
IEA-SSPS Almeria, Spain	Parabolic Trough	Oil Cast Fe	Oil	225	295	1 dual medium tank	100	4
Solar One Barstow, California, USA	Central Receiver	Oil Sand Rock	Steam	224	304	1 dual medium tank	3460	182
CESA -1 Almeria, Spain	Central Receiver	Molten salt	Steam	220	340	Cold tank Hot tank	200 200	12

THEMIS Targassonne, France	Central Receiver	Molten salt	Molten salt	250	450	Cold tank Hot Tank	310 310	40
Solar Two, Barstow, California, USA	Central Receiver	Molten salt	Molten salt	275	565	Cold tank Hot Tank	875 875	110

HYBRIDIZATION AND AUXILIARY SYSTEMS

Energy storage is closely associated with the issue of the use of auxiliary energy supplies. An optimal combination of conventional energy supplies and the renewable sources is desirable whenever possible. For instance, the use of auxiliary natural gas heating during the night in conjunction with thermal energy storage would significantly improve the capacity of solar thermal systems, and hence their economics.

The Integrated Solar Combined Cycle System, ISCCS is a design concept that integrates a parabolic trough plant with a gas turbine combined-cycle plant [2]. The ISCCS offers an innovative way to reduce cost and improve the overall solar-to-electric efficiency. The ISCCS uses solar heat to supplement the waste heat from the gas turbine in order to augment power generation in the steam Rankine bottoming cycle. In this design, solar energy is generally used to generate additional steam and the gas turbine waste heat is used for preheat and steam superheating. Most designs have looked at increasing the steam turbine size by as much as 100 percent. The ISCCS design will likely be preferred over the solar Rankine plant in regions where combined cycle plants are already being installed.

Coal hybrids can be used in regions with good solar resources where coal plants are currently used. Integration into a coal plant is used to either reduce coal consumption or add solar peaking, much like the ISCCS configuration. Due to the higher temperature and pressure steam conditions used in modern coal plants, the solar steam may need to be admitted in the intermediate or low-pressure turbine.

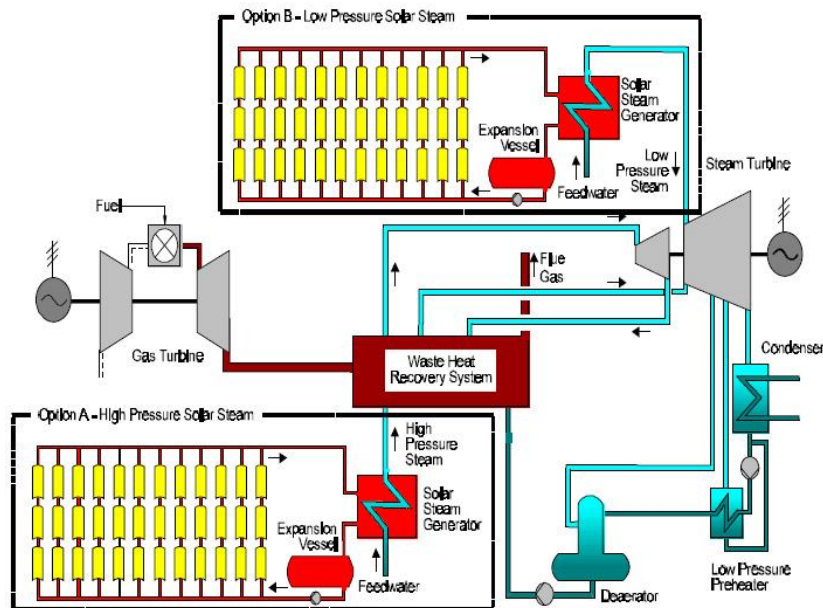

Figure 2. Integrated Solar Combined Cycle, ISCCS thermal system [2].

POWER CONVEYANCE AND TRANSPORT

The transport or conveyance of the stored energy from the location of its production to the consumption sites is of great importance for future sustainable systems. The use of High Voltage Direct Current (HVDC) for the transport of electricity from the high wind resources Great Plains to the East Coast in the USA, or solar and wind electricity across the Mediterranean Sea from North Africa to Europe are distinct possibilities.

The alternate use of hydrogen as an energy carrier whenever water is available would allow the storage conveyance of energy from both conventional and renewable sources. A superconducting electrical and cryogenic hydrogen conveyance system could be associated with a modern high speed Magnetically Levitated (Maglev) train system along the highway system corridors in North America.

USA INFRASTRUCTURE

In 2009 the American Society of Civil Engineers (ASCE) updated its 2005 report on the USA infrastructure. No area rated higher than a C+. Roads, aviation, and transit declined in score while dams, schools, drinking water, and wastewater held at D or lower. One category, energy, improved, from a D to a D+. The 2009 grades were:

- Aviation D
- Bridges C
- Dams D
- Drinking Water D-
- Energy D+
- Hazardous Waste D
- Inland Waterways D-
- Levees D-
- Public Parks and Recreation C-
- Rail C-
- Roads D-
- Schools D
- Solid Waste C+
- Transit D
- Wastewater D-
- America's Infrastructure GPA: D

The estimated 5 Year investment is \$2.2 Trillion. The 2009 fiscal stimulus package - the American Recovery and Reinvestment Act (ARRA) included \$72 billion for infrastructure upgrades, enough to cover just 6 percent of the 5 year infrastructure deficit estimated by the ASCE.

ELECTRICAL GRID

The ASCE's Report Card for America's Infrastructure gives the US Electric Grid a rating of D:

“The USA power transmission system is in urgent need of modernization. Growth in electricity demand and investment in new power plants has not been matched by investment in new transmission facilities. Maintenance expenditures have decreased 1% per year since 1992. Existing transmission facilities were not designed for the current level of demand, resulting in an increased number of "bottlenecks," which increase costs to consumers and elevate the risk of blackouts.”

“Our grids today are more stressed than they have been in the past three decades. If we don't expand our capacity to keep up with an increase in demand of 40 percent over the next 25 years, we're going to see healthy grids become increasingly less reliable. Today, with the grid operating flat-out, any disruption—like the downed transmission line that sparked the 2003 blackout in the Northeast—can cripple the network.”

EXERCISE

1. An electrical storage battery is charged from a power supply at 1 kW for an hour. If its efficiency is 60 percent, how long would it take to totally discharge it if it used to supply a load at 100 Watts?

2. Compare the Carnot Cycle thermal efficiency: $\eta_{Carnot} = 1 - \frac{T_{cold}}{T_{hot}}$,

for the following concepts:

1. Central receiver concept (e. g. Solar Two, Barstow, California, USA),
2. Parabolic trough concentrator concept (e. g. IEA-SPSS, Almeria, Spain).

Explain the reason for the difference.

REFERENCES

1. John A. Duffie and William A. Beckman, “Solar Energy Thermal Processes,” Wiley-Interscience, 1974.
2. “Status Report on Solar Thermal Power Plants,” Pilkington Solar International, Report ISBN 3-9804901-0-6, 1996.