

CHAPTER 1

FIRST HUMAN MADE REACTOR AND BIRTH OF NUCLEAR AGE

© M. Ragheb
8/18/2023

“The energy produced by the atom is a very poor kind of thing.
Anyone who expects a source of power from the transformation of these atoms is talking moonshine.”
Lord Ernest Rutherford, 1933

“The Almighty certainly never intended that people should travel at such breakneck speed.”
About trains travelling at 15 miles per hour.
Martin van Buren, 1830.

“War is cruelty.
There is no use trying to reform it.
The crueller it is, the sooner it will be over.”
USA General William Tecumseh Sherman

1.1 INTRODUCTION

The events that accompanied the birth of the nuclear age are described. The construction of the Chicago Pile Number 1 (CP-1) as the first human made nuclear reactor and the milestones in scientific progress that preceded and immediately followed it are considered. The success of the first man-made self-sustained chain reaction was followed by the code-named Manhattan Project, which culminated into the first and only use of nuclear weapons in warfare by the USA against Japan.

The distinction between a nuclear reactor and a nuclear device using an exponential neutron population growth model is discussed. Humanity's hope lies in using its acquired knowledge in constructive endeavors, and refraining from its use for destructive actions. This process still continues in the nuclear age and affects every human in some special way.

1.2 THE CHICAGO PILE NUMBER ONE, CP-1 REACTOR

The following coded message was sent from the Stagg Field at the University of Chicago to government officials in Washington DC:

“You will be interested to know that the Italian navigator has just landed in the New World, and the natives are friendly.”

The Italian navigator referred to was not Christopher Columbus (1451-1506), but Enrico Fermi (1901-1954). “The natives were friendly,” alluded to the success of a major experiment designated as the Chicago Pile Number 1: CP-1. A painting by artist Gary Sheahan that reconstructed the event showing Enrico Fermi's team is shown in Fig. 1.

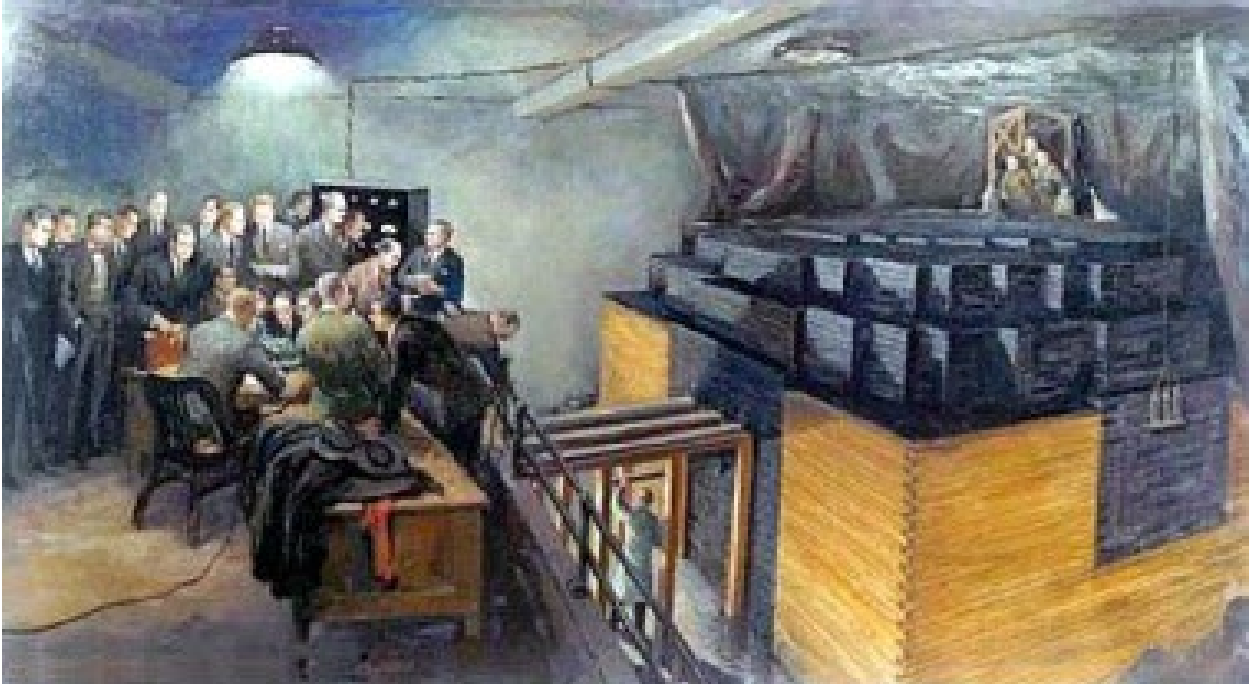

Figure 1. Painting by artist Gary Sheahan reconstructing the Chicago Pile Number 1 experiment: CP-1, first reactor showing Enrico Fermi's team; December 2, 1942.

Enrico Fermi was an experimental and theoretical physicist, born in Rome, Italy in 1901. He taught theoretical physics at the University of Rome in Italy. He was the co-inventor with Leo Szilard of the nuclear pile. He had received a Nobel Prize in Physics for atomic research in 1938: "On the absorption and diffusion of slow neutrons." He directed the building of the first reactor at the Metallurgical Laboratory at the University of Chicago. Enrico Fermi adhered to the Catholic Christian faith and was married to a Jewish spouse. He escaped the then prevalent nationalistic Fascism and Nazism in Europe to teach at Columbia University in the USA, where he became involved in the field of neutron physics.

Humans initiated a self-sustained nuclear chain reaction and controlled it for the first time on December 2, 1942. This occurred beneath the West Stands of Stagg Field, Chicago in the State of Illinois in the USA, at 3:25 in the afternoon.

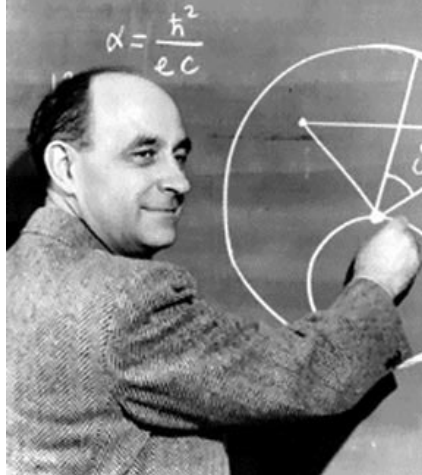

Figure 2. Enrico Fermi (1901-1954).

In the center of the 30 by 60 feet squash court, where it was constructed, the reactor consisted of a pile of graphite bricks and wooden timbers. It was square at the bottom and shaped as a sphere near the top. As an extra safety feature, it was shrouded on all but one side by a gray balloon cloth envelope, provided by the Goodyear rubber company, to contain any unexpected radioactivity release. Its sides were straight up to half its height, and the top was domed like a beehive. The squash court was situated under the ivy covered stands of the University of Chicago's Stagg Field, named after baseball's Grand Old Man: Amos Alonzo Stagg.

This experiment was part of an effort that started a few months earlier aimed at releasing energy from the nuclear fission process. The project was given the code name: "Manhattan District Project," in short: "The Manhattan Project." The objective was to build an explosive fission device. However, the scientists here were at the preliminary stage of investigating whether a self-sustained release of fission energy could be achieved in the first place.

Starting in April 1942, two test piles were built at the Stagg field in Chicago. By November 1942, Fermi and his coworkers had constructed a lattice of carbon blocks in the form of a graphite cube, containing lumps of uranium in the form of spheres.

The uranium was the fuel for the reaction while carbon, in the form of ultra-pure machined graphite, slowed down the neutrons originating from the fission process in the uranium fuel through collisions with the graphite nuclei from their average fission energy of about 2 Million electron Volts (MeV) down to the thermal equilibrium energy with the surrounding medium of 0.025 eV. This is a factor of:

$$\frac{2 \times 10^6}{0.025} = 80 \times 10^6$$

or an 80 million times reduction in energy.

It was then known that the nuclear fission process is more likely to occur in the rare U^{235} isotope, not the more abundant U^{238} isotope of uranium. In addition, the probability of fission of the isotope U^{235} , or its nuclear cross section, is enhanced if the neutrons are slowed down from their fast 2 MeV kinetic energy to the slow 0.025 eV thermal equilibrium energy. This is contradictory to classical physics where a large amount of kinetic energy would be more capable

of splitting the uranium nucleus. However, at these energies, the neutrons behave more like waves than particles. Under this circumstance, their wave behavior is best described by Quantum Mechanics, rather than by Classical Mechanics.

A simple heuristic model envisions the uranium nucleus as a potential well into which a sluggish slow neutron can drop and be readily absorbed as a wave, distributing its energy among the nucleons in the nucleus and causing it to fission. Conversely, a fast neutron as a wave would readily pass over the well, jumping over it without falling in and be captured into it.

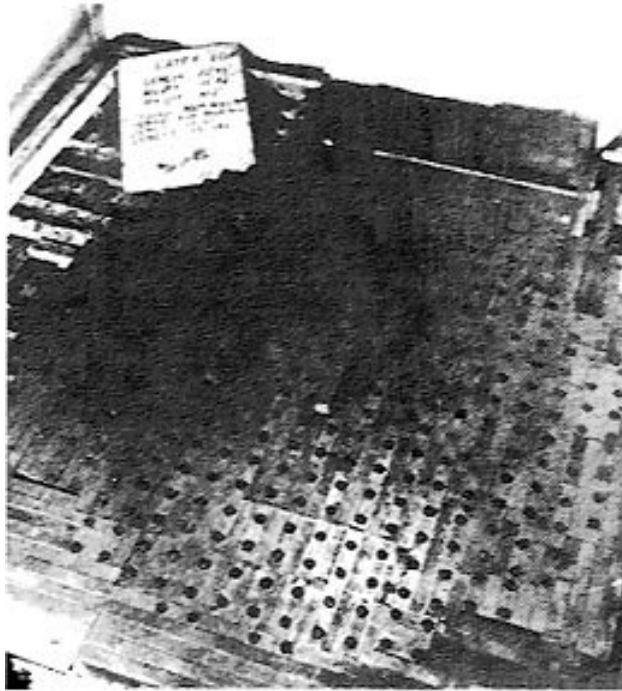

Figure 3. Tenth layer of the graphite blocks in CP-1 containing the lumped uranium spheres at the level of the tenth layer, 1942.



Figure 4. Graphite block from CP-1, Photograph courtesy: Paul Mikols.

It was also known that to use natural uranium for a chain reaction necessitates the use of a moderator material, which does not appreciably absorb the neutrons. From that perspective, carbon as graphite, beryllium or heavy water (HDO or D₂O) could be used, but *not* ordinary water (H₂O). Heavy water occurs in ordinary water, at a ratio of one molecule of heavy water in 6,700 molecules of ordinary water. The deuterium to hydrogen ratio on Earth is about: D/H = 160 parts per million (ppm).

Another important consideration was also known: that mixing a moderator with the natural uranium fuel in a homogeneous manner in the form of a slurry or a salt solution would not give a chance to the neutrons to slow down to the required thermal energy. A neutron originating from fission would get absorbed through resonance absorption in the U²³⁸ nuclei distributed evenly in the homogeneous mixture. Distributing separate lumps of the fuel into spheres embedded into the graphite blocks allows a neutron born through fission in the fuel to exit the fuel lump, find the nuclei of the moderator to collide with while slowing down in energy, and escaping to a great extent the process of being absorbed in the U²³⁸ nuclear cross section absorption resonances. Having escaped resonance capture in U²³⁸ and slowed down in the moderator, the now slowed-down neutrons can encounter another lump of fuel and fission some of the U²³⁵ isotope nuclei in it.

Blocks of ultra-pure graphite numbering about 4,000 and weighing 6 pounds each were carefully manufactured. Uranium spheres the size of baseballs were positioned into 22,000 holes that were carefully drilled in the graphite blocks. Figure 3 shows the layering of the graphite blocks containing the lumped uranium spheres at the level of the tenth layer. Instrumentation for measuring the neutron flux such as Geiger counters were built and calibrated to measure the radioactivity arising from the fission process.

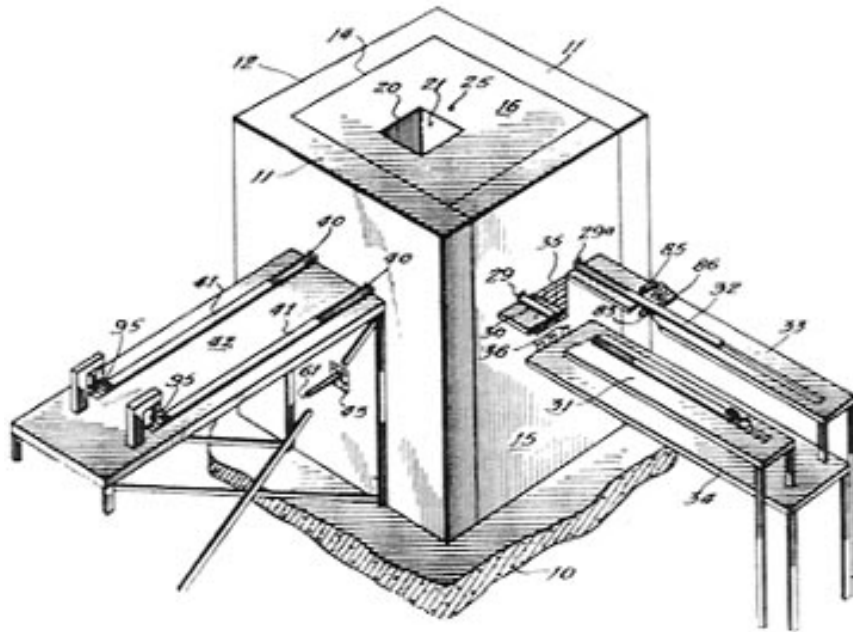

Figure 5. Diagram that was part of the patent 2,708,656 application in 1955 for the CP-1 reactor.
Source: USA Patent Office.

Control rods consisting of the strong neutron absorption material cadmium (Cd) were inserted through the pile to control, through neutron absorption, the fission process. For safety reasons, if the control rods were unable to shut down the chain reaction, buckets containing boric acid, with boron (B) as a strong neutron absorbing material, were ready to be poured on top of the pile should the control rods fail in shutting down the chain reaction.

Layer upon layer of the lumped moderator and fuel configuration, up to 56 layers, were added with the control rods withdrawn with the addition of each new layer. On December 2, 1942 the pile was almost complete, with only the last layer being added.

At 3:20 pm the nuclear age was born, when after 28 minutes the neutron flux was high enough to maintain a self-sustained nuclear fission reaction in a critical mass of natural uranium in a graphite moderator. The first man-made reactor, CP-1 generated just 1/2 Watt of power from the fission chain reaction using 771,000 lbs of graphite as a moderator material. As fuel material, it used 80,590 lbs of uranium dioxide (UO₂), and 12,400 lbs of uranium metal (U). It cost \$1 million to construct as a flattened rotational ellipsoid 25 ft wide and 20 ft high.

Patent number 2,708,656 was issued on May 18, 1955 to Enrico Fermi and Leo Szilard after World War II, for the CP-1 reactor design. Figure 5 shows a diagram that was part of the patent application.

1.3 THERMAL AND FAST NEUTRONS

The neutrons born from the fission process have an average kinetic energy of 1.99 MeV, and are designated as “fast neutrons.” They collide with the nuclei of carbon in the form of the graphite moderator multiple times and slow-down in energy until they reach thermal equilibrium with the moderator medium and are then designated as “thermal neutrons.”

The kinetic energy of thermal neutrons, or “kT neutrons,” is given by:

$$E_k = kT \quad (1)$$

where: k is the Boltzmann constant = 1.38×10^{-16} [erg / K]
 $T = 273 + ^\circ\text{C}$, is the kelvin temperature.

Incidentally, according to the 13th General Conference on Weights and Measures (CGCPM) in 1967, on the kelvin (K) temperature scale, temperatures are called “kelvins” without capitalization and the symbol K is not preceded by the degree symbol in contrast to the degree Celsius ($^\circ\text{C}$) and the degree Fahrenheit ($^\circ\text{F}$) scales.

The kinetic energy of the neutrons can be expressed as:

$$E_k = kT = \frac{1}{2}mv^2,$$

from which their speed v can be estimated from:

$$v = \sqrt{\frac{2E_k}{m}} = \sqrt{\frac{2kT}{m}} \quad (2)$$

EXAMPLE

We use Eqn. 1 to calculate the energy in eV of a thermal neutron in equilibrium with the moderating medium at a room temperature of 20 degrees Celsius as:

$$\begin{aligned} E_k &= kT \\ &= 1.38 \times 10^{-16} \frac{\text{erg}}{\text{K}} (273 + 20) \text{K} \frac{1}{1.61 \times 10^{-12}} \frac{\text{eV}}{\text{erg}} \\ &= 0.025114 \text{ eV} \\ &\approx 0.025 \text{ eV} \end{aligned}$$

EXAMPLE

We can then use Eqn. 2 to calculate the speed of the thermal neutrons as:

$$\begin{aligned}
v &= \sqrt{\frac{2E_k}{m_n}} \\
&= \sqrt{\frac{2 \times 0.025 \text{ eV} \times 1.6 \times 10^{-19} \frac{\text{Joule}}{\text{eV}} \times 10^7 \frac{\text{erg}}{\text{Joule}} \times \frac{\text{gm} \times \frac{\text{cm}}{\text{sec}^2} \times \text{cm}}{\text{erg}}}{1.675 \times 10^{-24} \text{ gm}}} \\
&= 2.185 \times 10^5 \frac{\text{cm}}{\text{sec}} \\
&\approx 2,200 \frac{\text{m}}{\text{sec}}
\end{aligned}$$

Thermal neutrons are thus also referred to as “2,200 m / sec neutrons.” Conversely, fast neutrons are close to having relativistic speeds and it may be argued that they warrant a relativistic treatment.

From the Special Theory of Relativity, for a relativistic particle, the Total Energy is expressed as:

$$\text{Total Energy} = \text{Kinetic Energy} + \text{Rest Mass Energy} \quad (3)$$

Expressed in terms of the mass of the neutron m_n and the square of the speed of light c , this equation can be written as;

$$m_n c^2 = E_k + m_{n0} c^2 \quad (4)$$

From this equation the kinetic energy of a relativistic particle is:

$$\begin{aligned}
E_k &= m_n c^2 - m_{n0} c^2 \\
&= (m_n - m_{n0}) c^2 \\
&= \Delta m_n c^2
\end{aligned} \quad (5)$$

The relativistic mass of the particle depends on the ratio of its speed v to the speed of light c as

$$\beta = \frac{v}{c} \quad (6)$$

It can be written as:

$$m_n = \frac{m_{n0}}{\sqrt{1 - \left(\frac{v}{c}\right)^2}} \quad (7)$$

Substituting for the relativistic mass Eqn. 7 into the expression for the kinetic energy Eqn. 5, we get:

$$\begin{aligned}
 E_k &= \left(\frac{m_{n0}}{\sqrt{1 - \left(\frac{v}{c}\right)^2}} - m_{n0} \right) c^2 \\
 &= \left(\frac{1}{\sqrt{1 - \left(\frac{v}{c}\right)^2}} - 1 \right) m_{n0} c^2
 \end{aligned} \tag{8}$$

The relativistic particle's speed can be expressed from Eqn. 8 as a fraction of the speed of light c as:

$$\begin{aligned}
 1 + \frac{E_k}{m_{n0} c^2} &= \frac{1}{\sqrt{1 - \left(\frac{v}{c}\right)^2}} \\
 1 - \left(\frac{v}{c}\right)^2 &= \frac{1}{\left(1 + \frac{E_k}{m_{n0} c^2}\right)^2} \\
 v &= \left[1 - \frac{1}{\left(1 + \frac{E_k}{m_{n0} c^2}\right)^2} \right]^{\frac{1}{2}} c
 \end{aligned} \tag{9}$$

EXAMPLE

The speed of a fission neutron born at an energy of 2 MeV can be calculated from Eqn. 9 as:

$$\begin{aligned}
v &= \left[1 - \frac{1}{\left(1 + \frac{2 \times 10^6 \text{ eV} \times 1.6 \times 10^{-12} \frac{\text{erg}}{\text{eV}}}{1.675 \times 10^{-24} \text{ gm} \times (3 \times 10^{10} \frac{\text{cm}}{\text{sec}})^2} \right)^2} \right]^{\frac{1}{2}} 3 \times 10^{10} \frac{\text{cm}}{\text{sec}} \\
&= \left[1 - \frac{1}{\left(1 + \frac{2 \times 1.6 \times 10^{-2}}{1.675 \times 3 \times 3} \right)^2} \right]^{\frac{1}{2}} 3 \times 10^{10} \frac{\text{cm}}{\text{sec}} \\
&= \left[1 - \frac{1}{1.004249} \right]^{\frac{1}{2}} \times 3 \times 10^{10} \frac{\text{cm}}{\text{sec}} \\
&= [0.004231]^{\frac{1}{2}} \times 3 \times 10^{10} \frac{\text{cm}}{\text{sec}} \\
&= 0.06505 \times 3 \times 10^{10} \frac{\text{cm}}{\text{sec}} \\
&= 1.95 \times 10^9 \frac{\text{cm}}{\text{sec}} \\
&= 1.95 \times 10^7 \frac{\text{m}}{\text{sec}}
\end{aligned}$$

This amounts to 6.5 percent of the speed of light.

Should the treatment use Eqn. 2, we would have obtained the closely similar result:

$$\begin{aligned}
v &= \sqrt{\frac{2E_k}{m_n}} \\
&= \sqrt{\frac{2 \times 2 \times 10^6 \text{ eV} \times 1.6 \times 10^{-19} \frac{\text{Joule}}{\text{eV}} \times 10^7 \frac{\text{erg}}{\text{Joule}}}{1.675 \times 10^{-24} \text{ gm}}} \\
&= 1.95 \times 10^9 \frac{\text{cm}}{\text{sec}} \\
&= 1.95 \times 10^7 \frac{\text{m}}{\text{sec}}
\end{aligned}$$

1.4 ETYMOLOGY OF THE WORD “SCRAM”

The etymology of the word “Scram,” meaning the sudden fast shutdown of a nuclear reactor, is that it is an acronym reportedly coined by Enrico Fermi, when he placed one of his colleagues, Norman Hillberry, next to a rope used to raise and lower the control rods into the CP-1 pile, equipped with an ax. Norman Hillberry's duty, if called upon, was to chop the rope with a single swing of the ax, immediately dropping the control rods, absorbing the neutrons, hence stopping the fission chain reaction.

The story goes that Norman Hillberry's title in the project was: “Safety Control Rod Ax Man,” hence the acronym “Scram.” There are not any ax men in the control rooms of modern nuclear power plants. There exist though plenty of red colored Scram switches sometimes labeled: “RX Trip,” RX standing for “Reactor Scram.” A 45 degree clockwise yank sends the control rods into the core and fission power of the reactor shuts down within seconds.

1.5 SCIENTIFIC MILESTONES

The successful experiment at the CP-1 reactor was preceded by a rapid succession of events in the study of radioactivity and nuclear processes. Antoine Henry Becquerel discovered radioactivity in France around 1896. Pierre and Marie Curie followed by discovering the element radium, and later polonium, and the chain decay of uranium in 1898. Their work was helped by other discoveries such as the discovery of the electron through experiments conducted with cathode ray tubes by J. J. Thomson in 1897.

The energy to mass equivalence equation was introduced by Albert Einstein in 1905. Ernest Rutherford conducted experiments where he bombarded a thin gold foil with alpha particles or He nuclei, and inferred the existence of the nucleus at the center of the atom's structure in 1912. This was followed by the discovery of the neutron by James Chadwick in 1932.

The discovered neutrons were used to induce artificial radioactivity by Irène and Frédéric Joliot-Curie in the 1930s in France. Enrico Fermi in Italy had conducted experiments producing new artificial isotopes using neutrons.

Otto Hahn and Fritz Strassmann in Germany bombarded uranium nuclei with neutrons, and found traces of new nuclei in the middle of the periodic table: this was the discovery of the fission process. They reported that when a nucleus of uranium was bombarded by neutrons, the uranium nucleus splits or, in the parlance of biology, fissions or splits like biological cells would do. It was later noticed that additional neutrons were emitted in the fission process. These neutrons become available for inducing further fission reactions with other uranium nuclei. This fact implied the possibility of a nuclear chain reaction, similar to the fusion nuclear reactions occurring in the sun and the stars. This chain reaction could be made self-sustaining, or critical, if a sufficient quantity of uranium could be brought together under the proper conditions that reduce absorptions within the volume and leakage from the surface of the material. If the system were supercritical, the nuclear energy release would increase exponentially until the material is expanded, burned-out and is no longer in a supercritical configuration. This situation can be the basis of a nuclear explosive device.

On the other hand, if the release is released in the critical controlled state, this energy can be harnessed for great benefit in electrical power production, fresh water desalination from the salty oceans, ship and rocket propulsion, isotopes production for nuclear medicine, harbor and canal excavation, defense against comet and asteroid astral assailants, and other uses requiring energy densities far exceeding the known sources of chemical energy.

Lise Meitner, who earlier worked with Otto Hahn in Germany and corresponded with him while she was in England, reported Otto Hahn's findings and explained its prospects to Niels Bohr in Norway, who fully understood its implications and in turn promptly communicated it to teams of scientists in England and the USA.



Figure 6. Leo Szilard with Albert Einstein re-enacting the writing of a letter addressed to President Franklin Roosevelt in 1939.

Leo Szilard convinced Albert Einstein, to jointly write a letter to USA President Franklin Roosevelt in 1939, urging him to initiate work on the possibility of building an atomic device. The Roosevelt Committee for the feasibility of an atomic device was established in 1941. In England, a similar committee was established: the Military Applications of Uranium Disintegration (MAUD) in 1941. The Army's Manhattan Engineer District Project, or Manhattan Project in short, was established in the USA under Brigadier General Leslie Grove from the Corps of Engineers in 1940.

As part of this project, work was initiated at the University of Chicago's Metallurgical Laboratory under Arthur Compton in 1942. The culmination of the effort was the first self-sustained man made fission chain reaction designated as Chicago Pile Number 1: CP-1.

ENERGY, MASS, RADIATION AND TEMPERATURE EQUIVALENCES

If we consider the energy and mass equivalence equation:

$$E_m = mc^2$$

and the electromagnetic energy equation:

$$E_\gamma = h\nu = h\frac{c}{\lambda}$$

and equate them to each other, we get:

$$E_m = E_\gamma = mc^2 = h\nu = h\frac{c}{\lambda}$$

$$m = \frac{h}{c^2}\nu = \frac{h}{c}\frac{1}{\lambda}$$

which suggests a possible equivalence between mass and electromagnetic radiation. High frequency ν or very short wave length λ radiation may possess a mass equivalence.

If we further consider the thermodynamic relation:

$$E_k = kT$$

we can write:

$$E_m = E_k = mc^2 = kT$$

Which also implies that:

$$m = \frac{k}{c^2}T$$

or another possible mass to temperature equivalence.

The radiant energy equation:

$$E_\sigma = \sigma T^4$$

implies:

$$E_m = E_\sigma = mc^2 = \sigma T^4$$

or:

$$m = \frac{\sigma}{c^2}T^4$$

another possible mass to temperature equivalence.

1.6 THE MANHATTAN PROJECT

Upon success of the CP-1 experiment, a nuclear device development effort project was promptly started in July 1943 with 100,000 employees at three then secret sites at a cost of \$2 billion. The USA feared that Germany, under the leadership of its leading nuclear scientist Werner Heisenberg, where fission was first discovered under Otto Hahn and Fritz Strassmann, was also on track for building such a weapon. Heisenberg had suggested the construction of a nuclear reactor using heavy water (D_2O) as a moderator, instead of the graphite used by Enrico Fermi. The Germans went on an unfruitful track and emphasized the use of thermal neutrons and were only able to build bulky subcritical assemblies which never achieved criticality. They also never reached the realization that fast neutrons can be used to construct a compact unmoderated fast neutron supercritical configuration and hence an explosive device.

Brigadier General Leslie Richard Groves, born in Albany, New York in 1896 from the USA Corps of Engineers (Fig. 7), who had earlier supervised the construction of the Pentagon building in Washington D. C., was chosen to direct the effort. He enlisted the help of scientists headed by Robert Oppenheimer (Fig. 8) who was a theoretical physicist, born in New York City in 1904. Oppenheimer, in turn, sought the help of an international team of scientists such as Enrico Fermi, Hans Bethe, Leo Szilard, Victor Weisskopf, Niels Bohr, George Kistiakowsky, and Edward Teller.



Figure 7. Brigadier-General Leslie Groves from the USA Corps of Engineers directed the Manhattan Project.



Figure 8. Robert Oppenheimer led the team of scientists at Los Alamos National Laboratory.

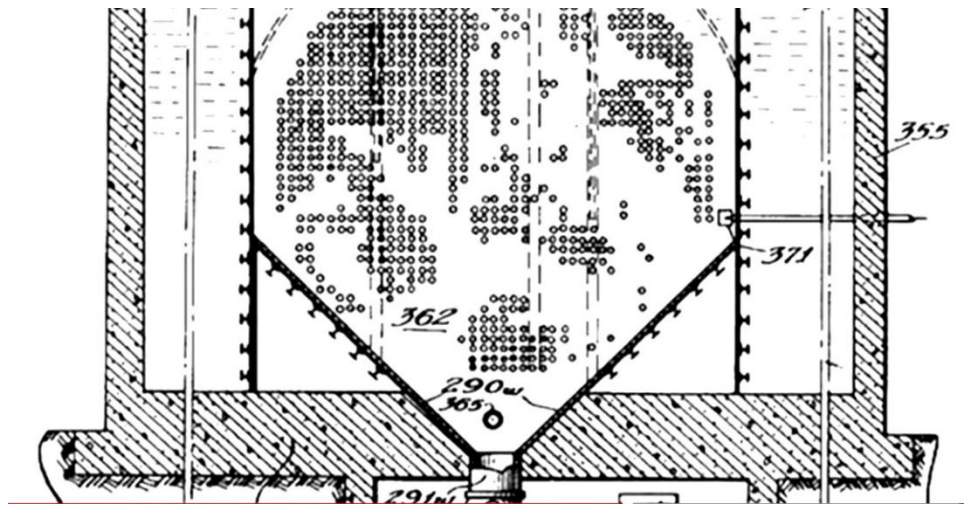
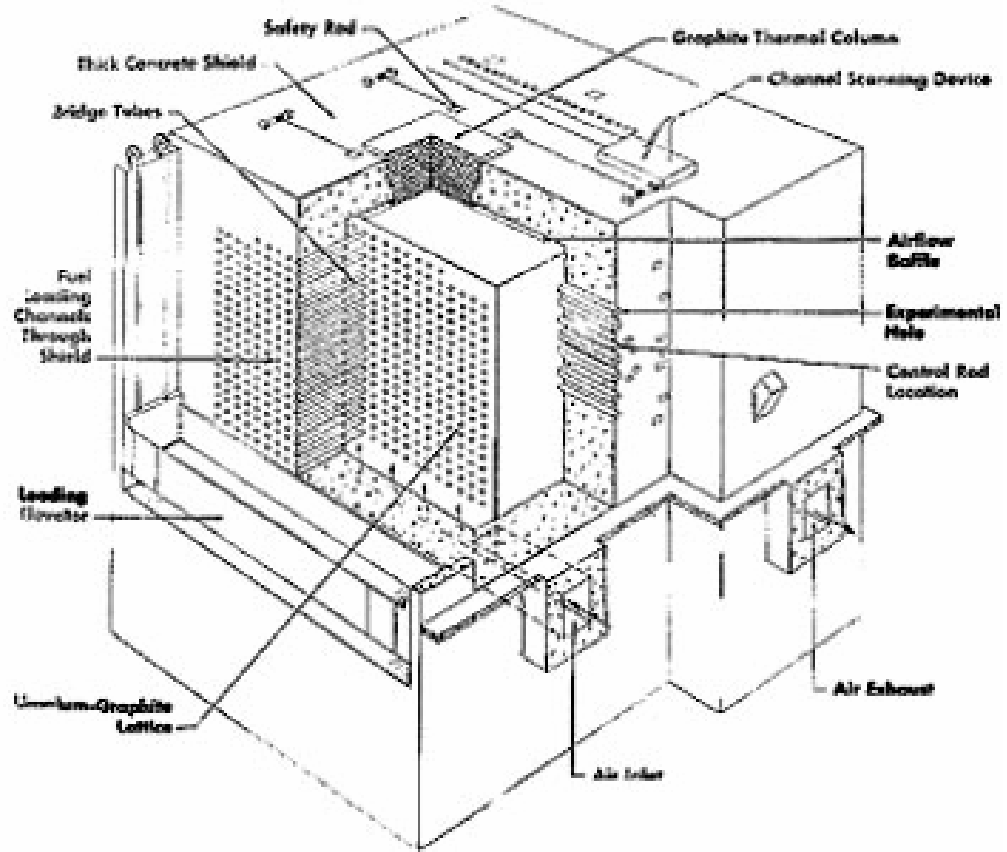

Figure 9. Cutout and patent detail through the air-cooled, face-loaded X-10 pile at Oak Ridge Tennessee, USA.

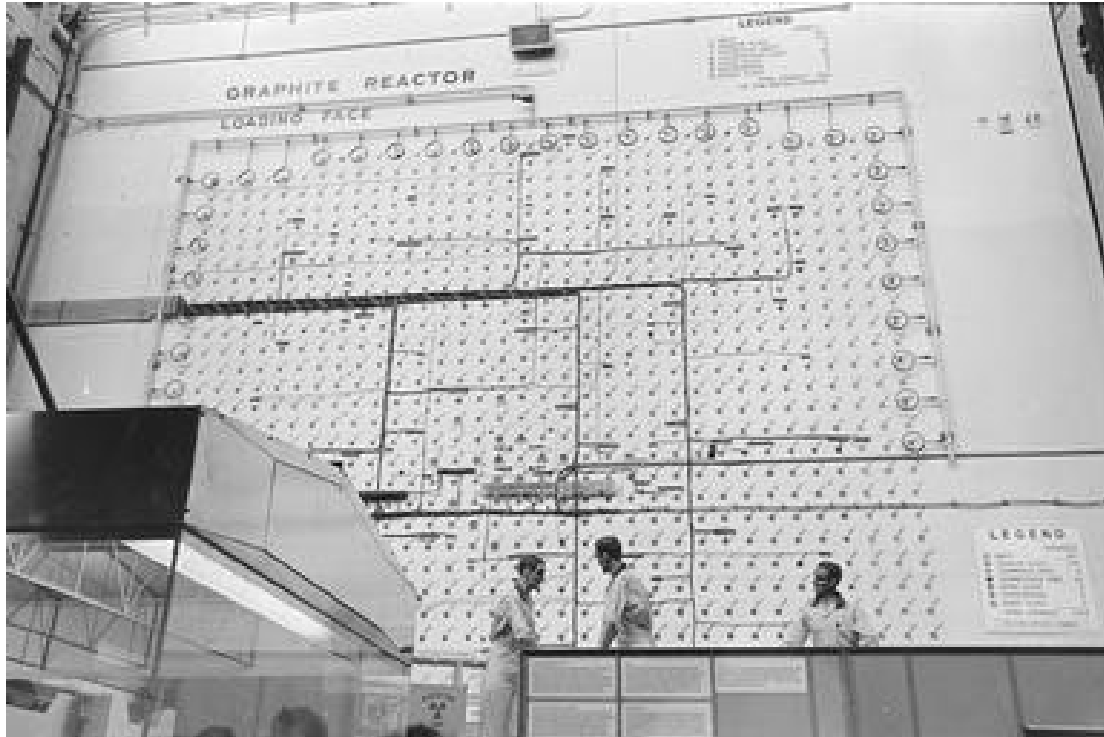

Figure 10. Loading face of the X-10 air-cooled Graphite Reactor constructed at the Clinton Engineers Works at Oak Ridge, Tennessee, USA.

A second pile designated as the Chicago Pile 2 or CP-2, using the uranium from the dismantled CP-1 pile, was constructed by March 1943 at Argonne National Laboratory (ANL) near Chicago. This new pile was surrounded by a five-foot thick concrete radiation shield. It was operated at a few kilowatts of power, compared with the $\frac{1}{2}$ watt power of CP-1, without an internal cooling system, producing small samples of plutonium for basic nuclear physics data and chemical separation experiments.

Another pilot experimental graphite moderated and air cooled pile at a design power level of 1,000 kilowatts or 1 Megawatt, designated as the X-10 pile was constructed at the Clinton Engineers Works near Oak Ridge, Tennessee in 1943. It was meant to provide enough plutonium for the chemical separation semi-works. It consisted of a large cube of graphite blocks surrounded by several feet of high density concrete as a biological shield against gamma ray radiation.

The graphite blocks were pierced by hundreds of horizontal diamond shaped channels, in which rows of cylindrical uranium slugs were fed horizontally, forming long rods. The pile was air cooled with circulation through the channels on all sides of the slugs. After a period of irradiation, new slugs would be fed from one face of the reactor, pushing the irradiated slugs to fall through a chute off the other side into a bucket immersed in water. After a few weeks of storage under water to allow the short-lived fission products radioisotopes to decay, the buckets were transferred through an underground canal to a chemical separation plant. A series of cells with thick concrete walls would contain chemical separation equipment operated remotely. Large underground tanks were used to store the radioactive waste. The facility was ingeniously located on a slope to make use of gravity for flow. Figures 9 and 10 show the X-10 air-cooled pile constructed at the Clinton Engineers Works.

The graphite blocks composing the X-10 pile measured 24 feet on the side and weighed 1,500 tons. It contained 1,243 channels in a grid on eight inches centers. The uranium slugs canned in aluminum jackets as cladding were 1.1 inch in diameter and 4.1 inches long. Two boron steel rods, in the right side of the pile controlled the power level of the chain reaction through inserting them in and withdrawing them out. Four more rods on the left side of the pile were used to shut down the pile. A hydraulic system was designed with two suspended weighted pistons, which would fall and drive the rods into the pile within 5 seconds in the event of a power failure. A second line of defense consisted of four rods suspended above vertical holes in the pile and dropping in when the trip mechanism is energized. As a third level of safety, two hoppers were filled with small boron steel balls to be released into vertical columns in an emergency. Air circulation traversed the graphite, went under the pile through a filter system to a 200 foot stack besides the building. A fan house contained a small steam-driven air circulator for emergency use, one 50,000 cubic feet per second fan, and another of 30,000 cubic feet per second capacity. Thermocouples to measure temperatures, a Pitot tube to measure air flow, and ionization chambers to measure the neutron flux levels were incorporated in the design feeding the information into an adjacent control room.

The pile reached criticality with 30 tons of uranium, or half of its 60 tons capacity. With improved cooling capabilities and increased fuel loading to 36 tons, the power level reached 500 kilowatts. Five tons of uranium metal containing just 500 milligrams, or half a gram of plutonium, was discharged in November of 1943. The power level eventually reached 1,800 kilowatts, about double its design level, but the amounts of plutonium produced were only sufficient for experimental purposes, and could not support a weapon's construction effort.

The real weapons engineering was a massive industrial effort that was carried out at three geographically dispersed sites. Large industrial complexes were constructed and managed by different industrial corporations. The DuPont Corporation managed the chemical works on a cost-plus basis in return for a symbolic payment of just \$1.

1.6 SITE W, THE HANFORD SITE, STATE OF WASHINGTON

The first site was designated as site W where five large-scale reactors and four smaller ones were built at the Hanford reservation in the state of Washington, using the neutrons resulting from the fission of the uranium²³⁵ isotope to breed the plutonium²³⁹ isotope as a fissile material from the uranium²³⁸ isotope in natural uranium. The reactors' power increased from the 1/2 watt of CP-1 to the 250 Megawatts thermal (MWth) power level. These reactors were water-cooled. Each pile needed a river pump house on the Columbia River, large storage and settling basins, huge motor driven pumps to deliver water to the faces of the reactors, and facilities for emergency cooling in case of power failure.

The first pile area was designated as 100-B. The nine reactors built were designated with letters as B, C, D, N, K and F. The tolerances in construction were exceptional. The allowable deviation in cross section measurements was 0.005 inch; in length, 0.006 inch; in the diameter of longitudinal holes for the process tubes, 0.003 inch. About 17 percent of the graphite used in the piles, was tested in a small 30 watts pile constructed at Hanford. The Hanford piles rose more than 120 feet above the desert floor. Adjacent to them were the water cooling treatment facilities, using the Columbia River water for cooling the reactors.

The irradiated uranium slugs were loaded into heavy shielded casks placed on special railroad cars operated by remote control, and moved about 5 miles away from the piles. The

buckets were suspended in water inside low concrete structures isolated in the desert. After a significant amount of the short lived radioactivity has been allowed to decay, the buckets were moved to the chemical separation plant.

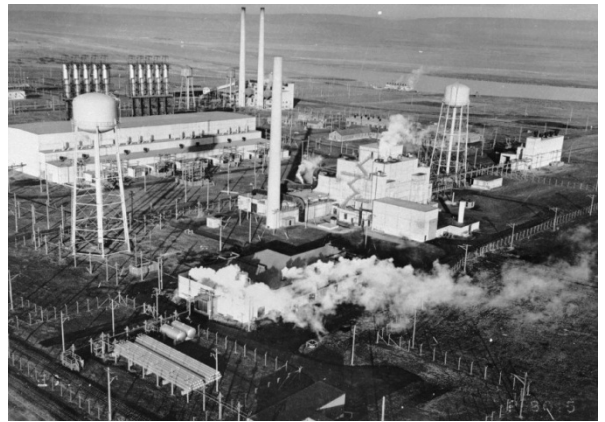



Figure 11. Views of the Hanford piles rising 120 feet above the desert floor with the water cooling treatment facilities, and the Columbia River in the background.



Figure 12. Assembly of the core of the C reactor at Hanford, state of Washington.

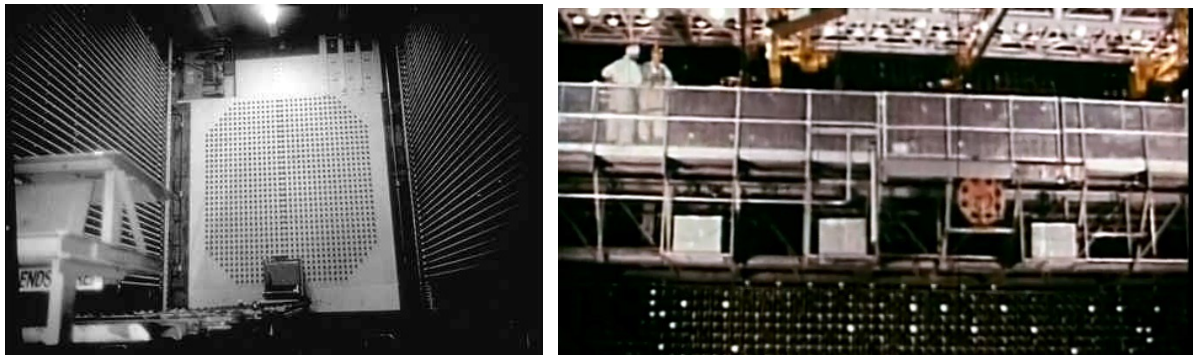

Figure 13. Loading face of the N graphite-moderated and water-cooled Reactor, Hanford, Washington.

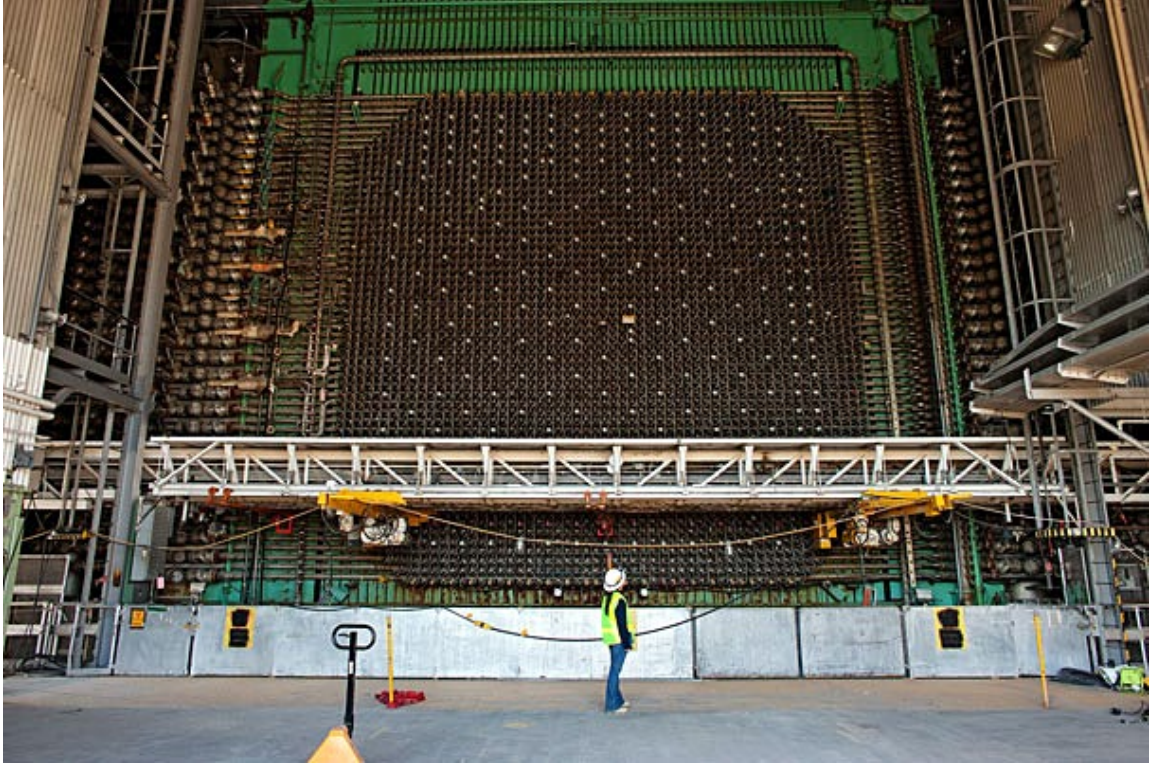

Figure 14. K reactor East face and loading platform at Hanford, Washington. Photo: Steve Featherstone.

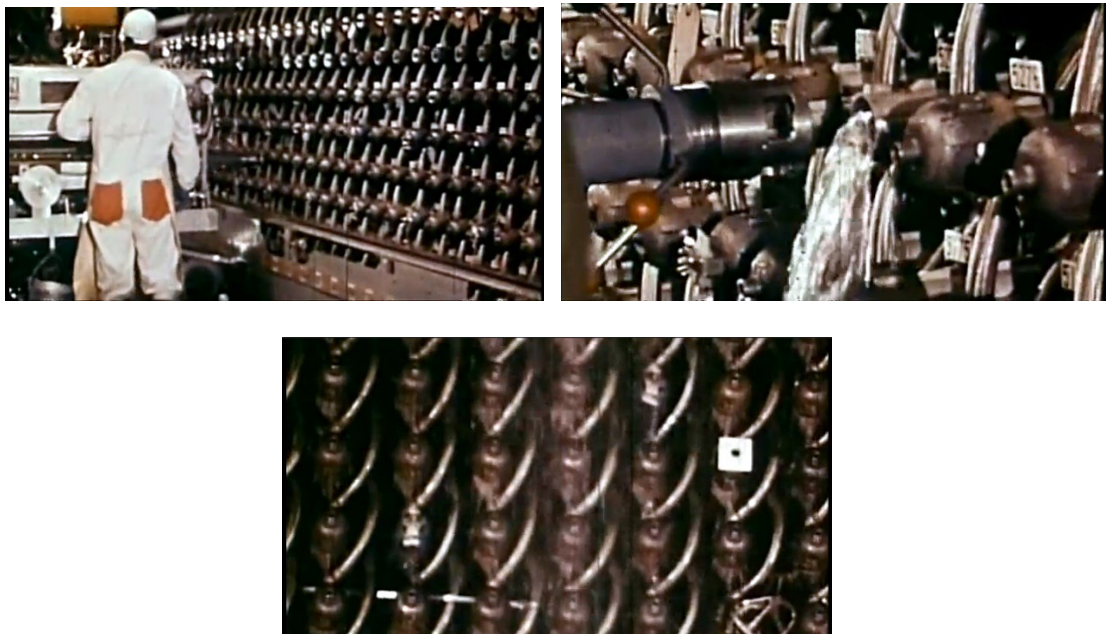

Figure 15. Water cooling channels in Hanford reactors.



Figure 16. Front and back faces of B reactor, Hanford.

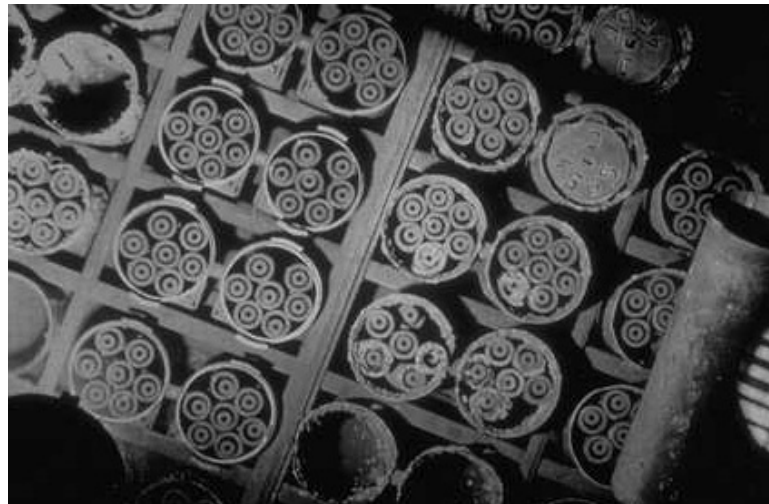

Figure 17. Spent fuel stored under water at the N reactor, Hanford, Washington.

A bismuth-phosphate chemical separation process extracted plutonium from the irradiated fuel in the separation building. The plutonium would be separated from the phosphate chemical carrier and other gross impurities in a concentration building. The phosphate carrier was dissolved in hydrochloric acid and the rare earth lanthanum fluoride was used to precipitate the plutonium. Disposal of radioactive gases and wastes from the process building were done in a ventilation building and a waste storage area.

There were three of these plants designated as T, U and B. The separation buildings, called canyons, were 800 feet long, 65 feet wide and 80 high. They resembled a large aircraft carrier floating on a sagebrush sea in the desert. In each one, a row of forty concrete cells, fifteen feet square and twenty feet deep, ran the length of the building. Each cell was covered by concrete blocks six feet thick, and was separated from its neighbors by six feet of concrete. The 35 tons concrete lids had to be poured maintaining a 1/8 of an inch tolerance to provide adequate shielding. The chemical separation plants were so large that they were called “canyons.”

Along one side of the cell row, and behind seven feet of concrete, were the operating galleries on three levels. The lowest level was for the electrical controls. The intermediate level was for piping and remote lubrication equipment. The upper level was for operating control boards. The area above the cells was enclosed by a single gallery sixty feet high and running the length of the building. Its five-foot concrete walls and three-foot roof slabs were designed to

prevent the escape of radiation when the cell covers were removed. Even with all the covers in place, radiation levels in the gallery would be so high that unprotected personnel could not be present. Once operation started, this huge gallery, or canyon as it became to be called, would become a silent concrete no-man's land isolated from the outside world.

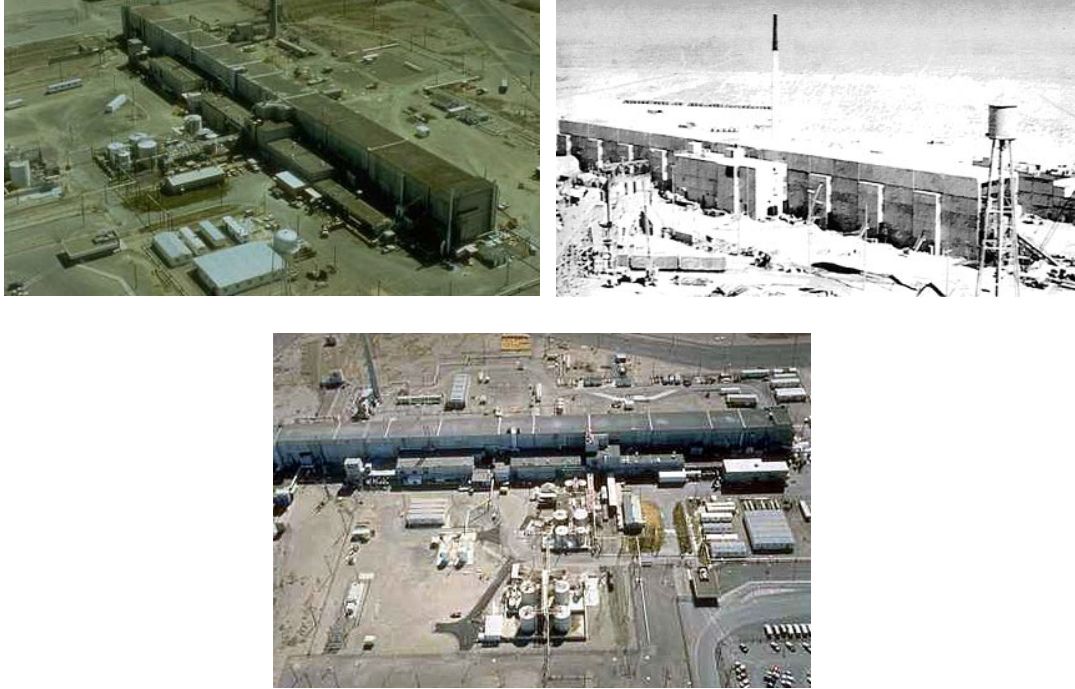

Figure 18. Purex process chemical separation canyons at the Hanford site.

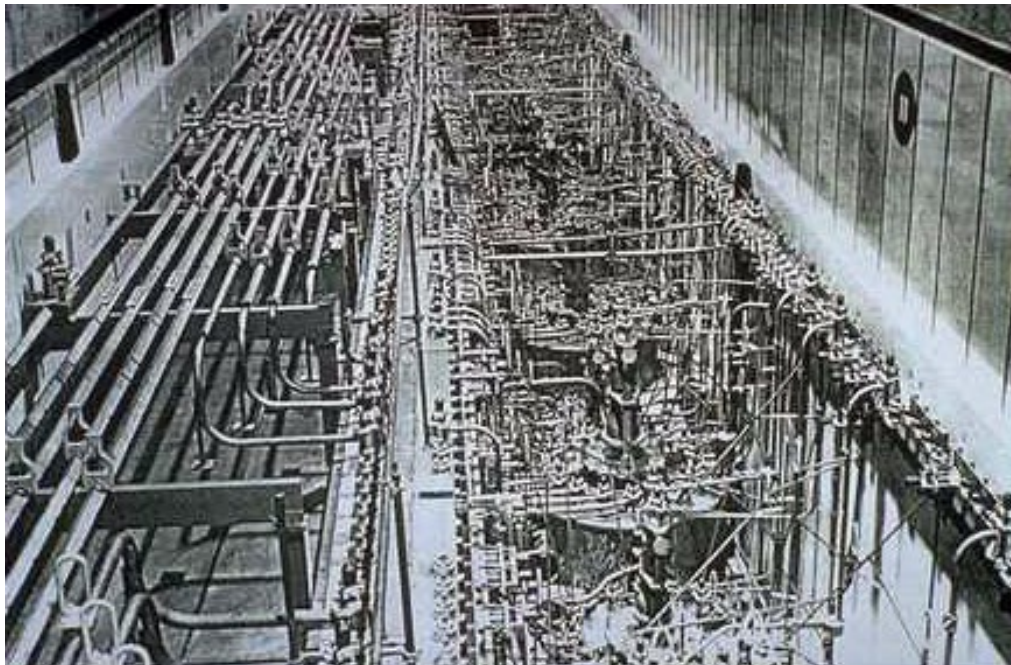

Figure 19. Interior view of the H reprocessing canyon.

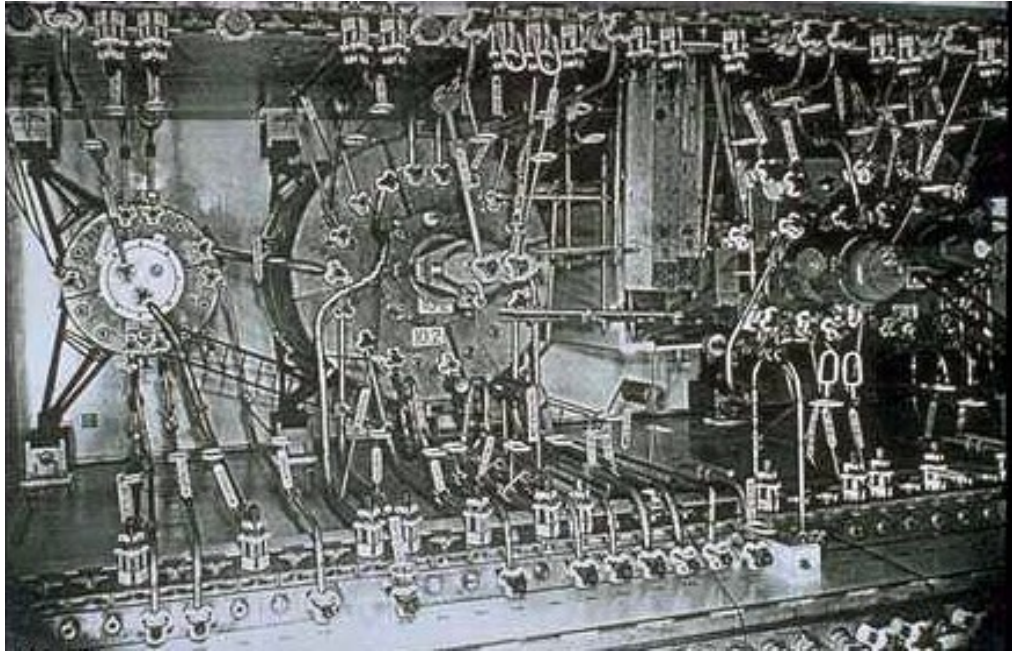

Figure 20. Canyon chemical processing tanks overhead view.



Figure 21. Reprocessing canyon F control room.

The intense radiation levels mandated the development of remote control equipment. This required simplicity of design, mechanical perfection, maintenance-free operation, and interchangeability of parts. Steam jets were used to transfer process materials from one tank to another, to avoid servicing pumps and valves. Centrifuges, being more reliable than filters, were developed for separating materials. Liquid level and density meters were used to follow the progress of the operation.

Once the plant was operating, the only access to the cells would be by means of large bridge cranes, which traveled the length of the building. From the heavily shielded cab behind a concrete parapet above the gallery, operators used periscopes and video monitors to view the inside of the gallery. They could use a seventy-ton hook to lift off the cell covers and lighter equipment to work within the cell. With impact wrenches and special tools, they could remove connecting piping, lift the damaged pieces of equipment, and isolate it in a storage cell. They would then lower another new piece of equipment into the operating position and reconnect the process piping. All of this was done at sixty feet or more without direct vision, and with the requirement of extreme accuracy in the dimensions of cell components. Equipment and connections were standardized. Distinctive color codes were used on all units. All concrete faces were coated with paint that is easily washable, corrosion resistant and adequately adherent to the concrete. Because the chemicals were highly corrosive, a special grade of niobium (columbium) stainless steel was used.

The final stage in plutonium recovery involved a peroxide method. This process was based on the fact that all nitrates, except those of uranium, thorium and plutonium, are soluble in hydrogen peroxide. The plutonium could be isolated, by separating it from the lanthanum-fluoride carrier, converting it into a nitrate, and adding peroxide. The product would be pure plutonium nitrate, which was then sent to the Los Alamos laboratory in New Mexico for reduction to metal. The great value and high toxicity of the product required specialized laboratory techniques.

1.8 SITE X, OAK RIDGE, TENNESSEE

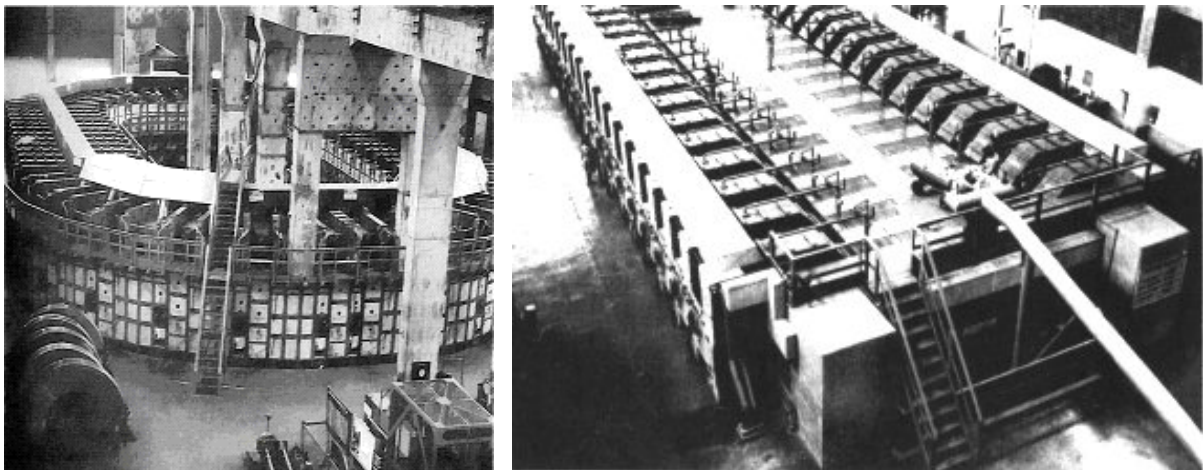

Figure 22. The Alpha I racetrack Calutron (left) and the Beta track (right) used at the Y-12 electromagnetic separation plant at Oak Ridge, Tennessee.

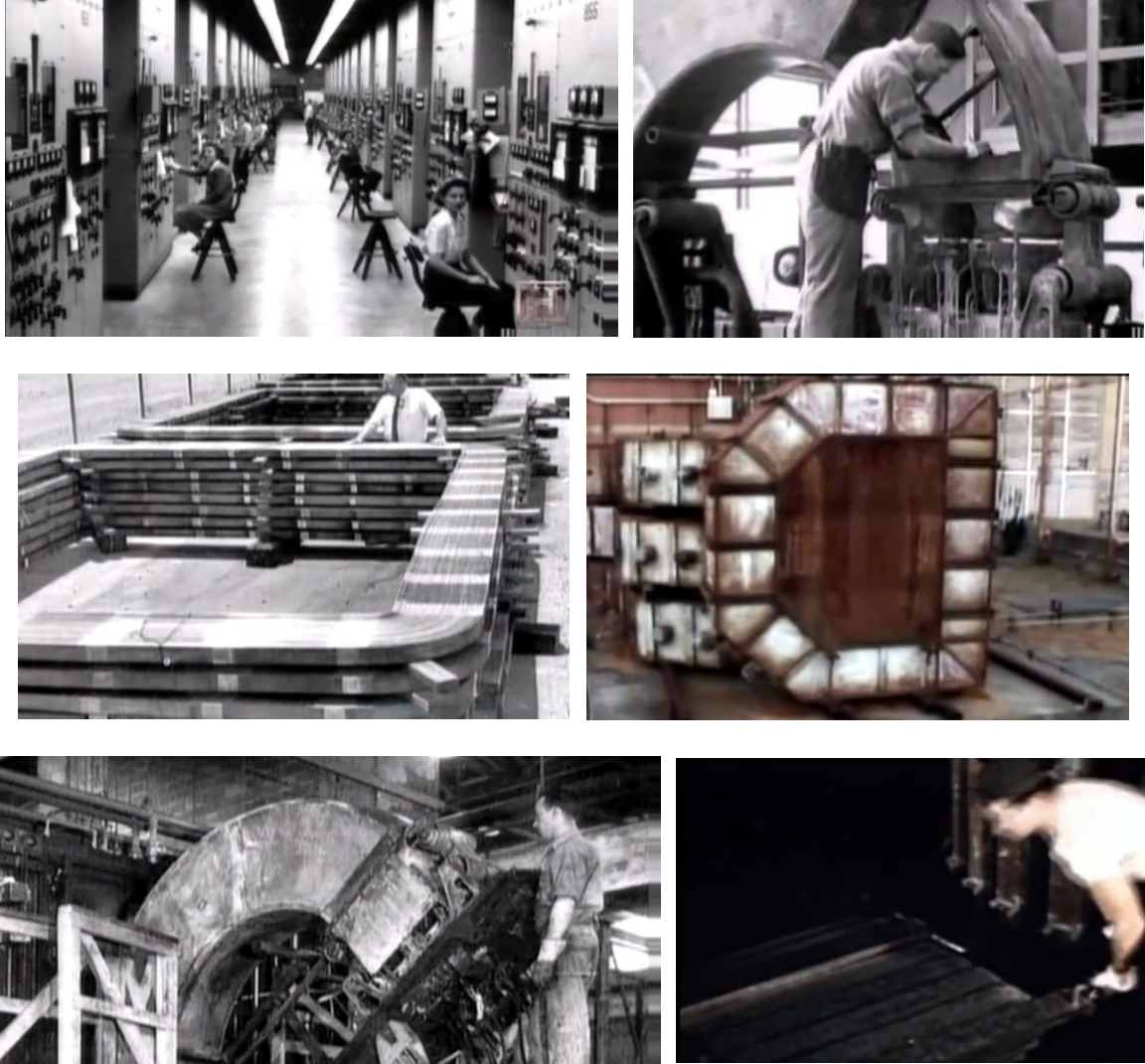

Figure 23. “Calutron Girls” controllers, vacuum chambers and magnet coils. About 14,000 tons of silver bars were borrowed from Fort-Knox strategic stockpile for the Calutron conductors.

The second site was designated as site X where scientists were isotopically separating the fissile U^{235} isotope from natural uranium using electromagnetic separation in 184 inch cyclotrons called Calutrons deriving their name from: “California cyclotrons.” The machines are essentially mass spectrographs that use magnetic fields to separate elements according to their mass and can produce any isotope on demand.

Copper for manufacturing of the magnet coils at the Y-12 site was in short supply and was allocated to the war effort. An amount of 14,700 tons or about 470 million ounces from the strategic metals silver stockpile of the Treasury Department at Fort Knox was used instead of copper, and was returned back in the 1990s when the Calutrons were shut down. There were 32 of them, with 8 of them devoted to Pu processing. About 200 grams of the U^{235} isotope were produced for experimental investigations during the war period. The Calutrons were retrofitted and resumed operation in 1995 after a 3 years shutdown and continued producing stable isotopes such as Thallium²⁰¹ used in heart scans, until they stopped operation in 1999, being unable to

compete with “Russian Calutron marketing” of stable isotopes produced at the closed city of Sverdlovsk. The Isotope Program had a large enough inventory of most stable isotopes to last for 4-5 years.

The Calutrons have been placed in a “cold standby” status, which would allow for a restart, although prospects for that are remote. Decisions were pending on whether and when to commence final dismantlement, which would involve draining cooling oil that contains Poly Chlorinated Biphenyls (PCBs) from their transformers and electromagnets.

The Electromagnetic separation process was a monumental white elephant designated as the Y-12 plant. It produced only a few grams of impure U^{235} and had to be closed after repetitively breaking down. Figure 22 shows the alpha and beta race tracks used in the electromagnetic process at Oak Ridge, Tennessee. The protruding ribs are the silver-wound magnet coils. The box-like cover on top contains a solid silver bus-bar. Two types of tracks were used: the Alpha I track for an initial enrichment, and the Beta rectilinear racetrack to reach higher enrichments and allowing a smaller scale of the equipment.

Other enrichment processes such as thermal diffusion and centrifugation were tried at this time, without producing significant amounts of the U^{235} isotope.

The main success in the production of U^{235} was carried out in the K-25 Gaseous Diffusion enrichment plant using 4,000 separation cells and uranium hexafluoride (UF_6), consuming as much electricity as New York City. The electricity needs were provided by Coal and Hydroelectric power plants operated by the Tennessee Valley Authority (TVA) government electrical utility agency.

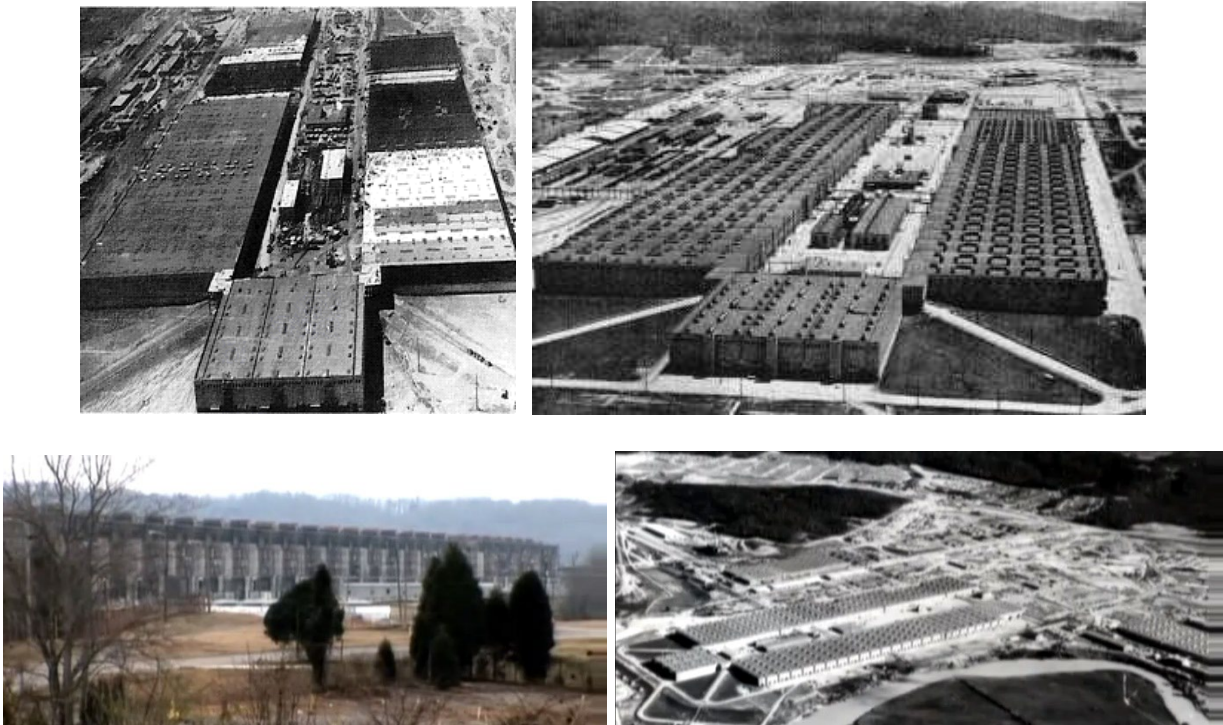

Figure 24. The one-mile in length K-25 gaseous diffusion plant, at Oak Ridge, Tennessee, was closed in 1987.

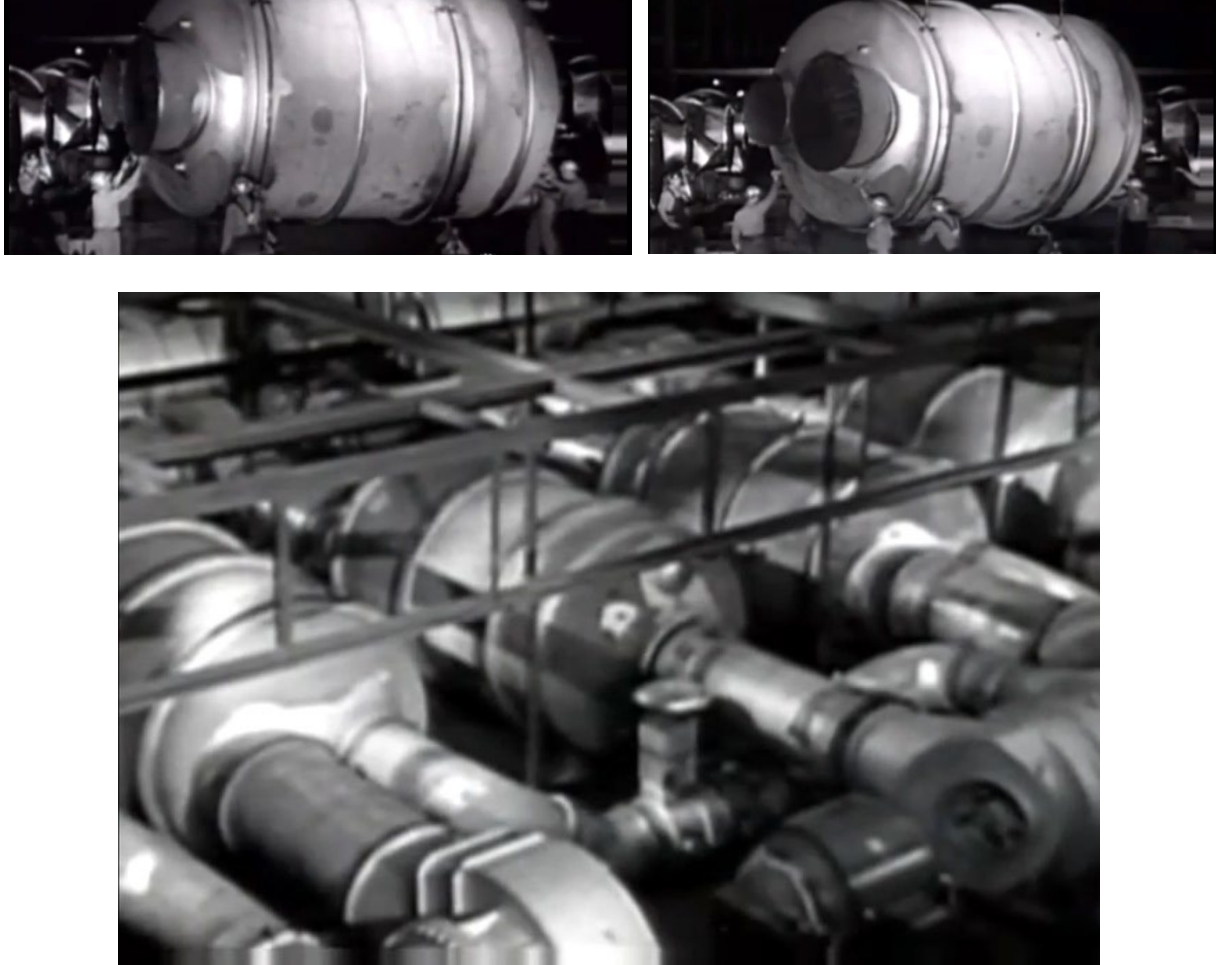

Figure 25. Cascade of gaseous diffusion enrichment cells.

Centrifugal pumps designs, with appropriate seals, operating in the highly corrosive environment of uranium hexafluoride (UF_6) had to be developed. Nickel-plating and nickel steel alloys resisted corrosion by the gas, and were used. This was the basis of the development of stainless steel as a spinoff industrial product. A barrier material capable of maintaining a separation capability over a long period of time without being clogged had to be chosen. It had to be submicroscopic, but not susceptible to clogging. It had to be porous, but solid enough to be manufactured. Nickel barriers involving a complex ten steps manufacturing process were initially used. Later development of a nickel powder barrier, possibly sintered powder, replaced the initial metallic barrier. Figure 24 shows the K-25 gaseous diffusion plant. In the center lie different service buildings.



Figure 26. Uranium hexafluoride UF_6 storage cylinders.



Figure 27. Depleted Uranium (DU) storage cylinders.

About 50 kilograms of highly enriched uranium were produced at Oak Ridge over a year's time for the Little Boy device, which was dropped on Hiroshima in 1945. The East Tennessee Technology Park nowadays is a former K-25 uranium-enrichment site.

Oak Ridge is currently the USA Department of Energy's largest science and energy laboratory. Between 1942 and 1945, as part of the Manhattan Project, it turned the rural countryside about 20 miles west of Knoxville, Tennessee into a semi-autonomous secret city inhabited by 75,000 people.

1.9 SITE Y, LOS ALAMOS, NEW MEXICO

The third site Y was situated at Los Alamos in New Mexico. Its objective was to create a critical mass using the fissile isotopes manufactured at the two other sites. There existed an uncertainty about which of the two fissile isotopes U^{235} or Pu^{239} would be suitable for constructing a weapon. There was concern about the process of spontaneous fission generating a neutron source in the different plutonium isotopes, and whether a device could be built from it. Spontaneous fission would initiate the fission reaction before a supercritical mass is fully assembled and such a device would prematurely fizzle releasing a minor amount of energy. The assembly of such a device would have to proceed at a much faster speed than in a gun barrel, necessitating an inverse rocket process designated as “implosion.” The production of both the isotopes was thus pursued. The group working on one isotope did not know about the existence of the other group.

Ultimately both approaches were successful, culminating in, not just one, but two fission device designs. The first design that was developed was a gun barrel type design using U^{235} . The second design was an implosion type device using Pu^{239} .



Figure 28. Inert gas plutonium glove box.



Figure 29. Finished plutonium puck or button (left) and enriched uranium ingot (right).

The intended target for these weapons was unequivocally Germany, but the war with Germany had already ended with its surrender. The Manhattan project was initiated out of fear that Germany was developing a fission weapon. The Germans under Werner Heisenberg had a modest primarily theoretical effort directed at building a subcritical reactor using heavy water as a moderator material. The production of heavy water available to Germany and its separation from ordinary water required the use of electricity produced from hydroelectric power in Norway in the water electrolysis process. Aerial bombardment, sabotage and a commando raid sunk the shipments of D_2O to Germany and disabled the heavy water plant twice. This concerted effort, whose purpose was not clear to Germany, but whose implications were fully understood by the Allies, brought a halt to the German effort. An investigative team, called the Alsos team, investigated the assumed German program at the end of the war in Europe in 1944. The team discovered that the much feared German weapon project was misguided and inconsequential.

The war with Japan was still ongoing, and the use of the developed weapons against Japan was promptly considered. Japan, realizing that it will eventually lose the war, fearing the entry into the war by Russia and its occupation of its northern islands, and preferring to reach an accommodation with the USA, now that the war in Europe had come to an end, was sending feelers and trying to negotiate an end to it.

There was some opposition among scientists and political personnel against the use of the atomic bomb, with suggestions of first demonstrating it as a warning to Japan before its actual use. Questioning the need for using the atomic bomb in the war against Japan, and fully aware of its vast destructive potential, James Conant and Vannevar Bush, at the urging of scientists working on the Manhattan Project, addressed a letter on September 30, 1944, to Secretary of war Stimson. They urged a demonstration of the weapon's capability before its use against Japan. Arthur Compton in May 1945, wrote a letter to superiors where he raised the "... question of mass slaughter for the first time in history." Niels Bohr in July 1944 sent a warning to the USA president that: "... any advantage the atomic bomb might seem to possess would be outweighed by a perpetual menace to human security." He had correctly predicted the nuclear arms race that would follow later. James Frank on June 12, 1945 led seven atomic scientists from the University of Chicago in presenting the Chicago Petition or the Frank Report. Farrington Daniels, director of the Metallurgical Laboratory at the University of Chicago, on July 12, 1945, polled 150 scientists working on the weapon project. A majority favored some form of demonstration of the device. Sixty eight scientists at Oak Ridge recommended demonstration of the weapon.

In the diary of then President Harry Truman, he made the case that atomic devices are purely military weapons:

“We have discovered the most terrible bomb in the history of the world. It may be the fire destruction prophesized in the Euphrates Valley Era, after Noah and his fabulous Ark. This weapon is to be used against Japan. [We] will use it so that military objectives and soldiers and sailors are the target and not women and children. Even if the Japs are savages, ruthless, merciless and fanatic, we as the leader of the world for the common welfare cannot drop that terrible bomb on the old capital or the new. The target will be a purely military one.”

DROPPED WARNING LEAFLETS ON JAPANESE CITIES

According to: Richard S. R. Hubert, “The OWI Saipan Operation,” Official Report to US Information Service, Washington, DC 1946:

“On August 1, 1945, five days before the bombing of Hiroshima, the U.S. Army Air Force dropped one million leaflets over Hiroshima, Nagasaki, and 33 other Japanese cities warning that those cities were going to be destroyed within a few days and advising the residents to leave to save their lives. One side of the leaflet had a photo of five U.S. bombers unloading bombs and a list of the targeted cities. The other side had the text. The English version of the leaflet is included in an [article](#) at the CIA website, “The Information War in the Pacific, 1945,” by Josette H. Williams. OWI stands for Office of War Information:

Front side of OWI notice #2106, dubbed the “LeMay bombing leaflet,” which was delivered to Hiroshima, Nagasaki, and 33 other Japanese cities on 1 August 1945. The Japanese text on the reverse side of the leaflet carried the following warning:

“Read this carefully as it may save your life or the life of a relative or friend. In the next few days, some or all of the cities named on the reverse side will be destroyed by American bombs. These cities contain military installations and workshops or factories which produce military goods. We are determined to destroy all of the tools of the military clique which they are using to prolong this useless war. But, unfortunately, bombs have no eyes. So, in accordance with America’s humanitarian policies, the American Air Force, which does not wish to injure innocent people, now gives you warning to evacuate the cities named and save your lives. America is not fighting the Japanese people but is fighting the military clique which has enslaved the Japanese people. The peace which America will bring will free the people from the oppression of the military clique and mean the emergence of a new and better Japan. You can restore peace by demanding new and good leaders who will end the war. We cannot promise that only these cities will be among those attacked but some or all of them will be, so heed this warning and evacuate these cities immediately.”

LEO SZILARD SECOND LETTER

Leo Szilard who ironically had earlier written a letter with Albert Einstein to President Franklin Roosevelt, urging the start of the bomb development project, found himself with 69 other scientists writing a petition to President Harry Truman asking him to first demonstrate the use of the atomic bomb to Japan before using it: "A study done for Secretary of War Henry Stimson's staff by William Shockley estimated that invading Japan would cost 1.7-4 million American casualties, including 400,000-800,000 fatalities, and five to ten million Japanese fatalities.

SECRET

July 17, 1945

A PETITION TO THE PRESIDENT OF THE UNITED STATES

Discoveries of which the people of the United States are not aware may affect the welfare of this nation in the near future. The liberation of atomic power which has been achieved places atomic bombs in the hands of the Army. It places in your hands, as Commander-in-Chief, the fateful decision whether or not to sanction the use of such bombs in the present phase of the war against Japan.

We, the undersigned scientists, have been working in the field of atomic power. Until recently we have had to fear that the United States might be attacked by atomic bombs during this war and that her only defense might lie in a counterattack by the same means. Today, with the defeat of Germany, this danger is averted and we feel impelled to say what follows:

The war has to be brought speedily to a successful conclusion and attacks by atomic bombs may very well be an effective method of warfare. We feel, however, that such attacks on Japan could not be justified, at least not unless the terms which will be imposed after the war on Japan were made public in detail and Japan were given an opportunity to surrender.

If such public announcement gave assurance to the Japanese that they could look forward to a life devoted to peaceful pursuits in their homeland and if Japan still refused to surrender our nation might then, in certain circumstances, find itself forced to resort to the use of atomic bombs. Such a step, however, ought not to be made at any time without seriously considering the moral responsibilities which are involved.

The development of atomic power will provide the nations with new means of destruction. The atomic bombs at our disposal represent only the first step in this direction, and there is almost no limit to the destructive power which will become available in the course of their future development. Thus a nation which sets the precedent of using these newly liberated forces of nature for purposes of destruction may have to bear the responsibility of opening the door to an era of devastation on an unimaginable scale.

If after this war a situation is allowed to develop in the world which permits rival powers to be in uncontrolled possession of these new means of destruction, the cities of the United States as well as the cities of other nations will be in continuous danger of sudden annihilation. All the resources of the United States, moral and material, may have to be mobilized to prevent the advent of such a world situation. Its prevention is at present the solemn responsibility of the United States--singled out by virtue of her lead in the field of atomic power.

The added material strength which this lead gives to the United States brings with it the obligation of restraint and if we were to violate this obligation our moral position would be weakened in the eyes of the world and in our own eyes. It would then be more difficult for us to live up to our responsibility of bringing the unloosed forces of destruction under control.

In view of the foregoing, we, the undersigned, respectfully petition: first, that you exercise your power as Commander-in-Chief, to rule that the United States shall not resort to the use of atomic bombs in this war unless the terms which will be imposed upon Japan have been made public in detail and Japan knowing these terms has refused to surrender; second, that in such an event the question whether or not to use atomic bombs be decided by you in the light of the considerations presented in this petition as well as all the other moral responsibilities which are involved.

R. Shapp

B. B. Mulliken

E. P. Wigner

George J. Moray

Leo Szilard

J. G. Wilson

J. F. Zuckerman

Francis R. S. Honka

John A. Simpson

Walter Barlow

John R. Hower

Frank Fote

DECLASSIFIED
NR 75 01 30
By _____
DATE _____

Figure 30. Declassified Leo Szilard petition to President Harry Truman with 69 other scientists on July 17, 1945 urging restraint before the use of the bomb. After Germany had surrendered in May 1945, Japan continued the war in Asia. The USA hoped that dropping a nuclear bomb after Japan rejected an earlier ultimatum would force a quick surrender without risking USA and Japanese casualties on the ground. When no immediate surrender came from the Japanese, USA forces dropped a second bomb three days later, on the city of Nagasaki. Source: USA National Archives.

The Allied Prisoners of War, POWs may have been factored in: "Japanese military directives ordered the execution of all POWs being held if Japan was ever invaded. Towards the end of the war about 100,000 Allied prisoners were in Japanese custody."

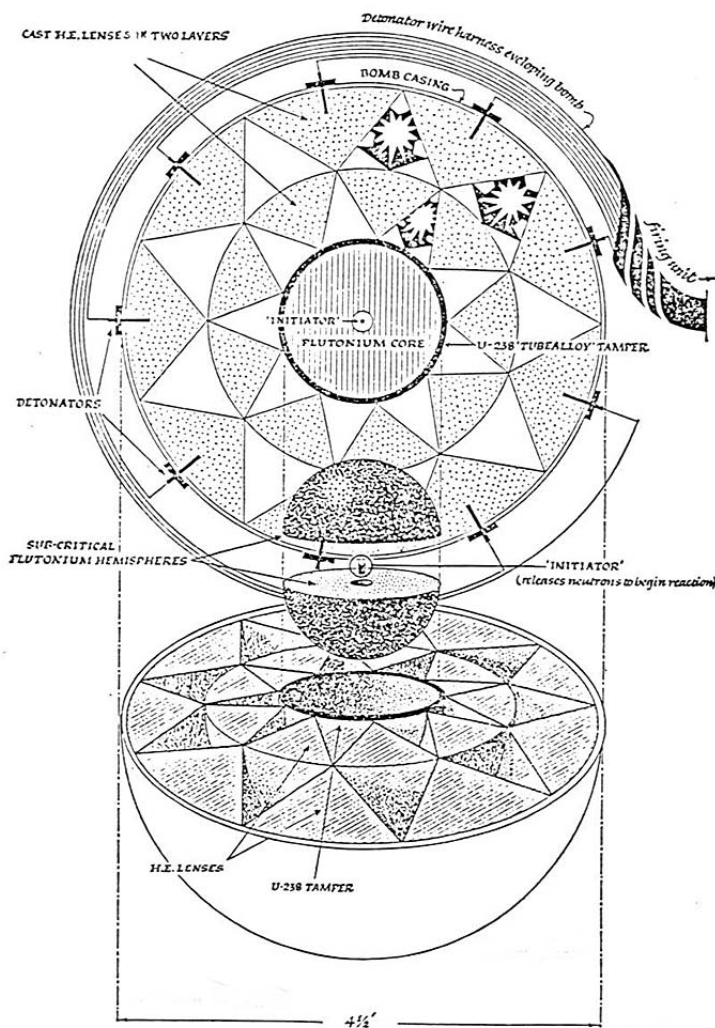

Figure 31. Assumed schematic of the Trinity plutonium device designated as "The Gadget" surrounded by the chemical explosive lenses initiators. Source: Gamow, "The Curve of Binding Energy."

From May to July 1945, a committee designated as the “Interim Committee’ studied the implications of using the atomic bomb. It was composed of the following members: Henry Stimson, George Harrison, James Byrnes, Ralph Bard, William Clayton, Vannevar Bush, James Conant, Arthur Compton, Enrico Fermi, Ernest O. Lawrence, and J. Robert Oppenheimer.

The Interim Committee, after deliberation, recommended the use of the bomb on Japan on a dual target without prior warning. Navy Under-Secretary Ralph Bard dissented and withdrew his agreement.

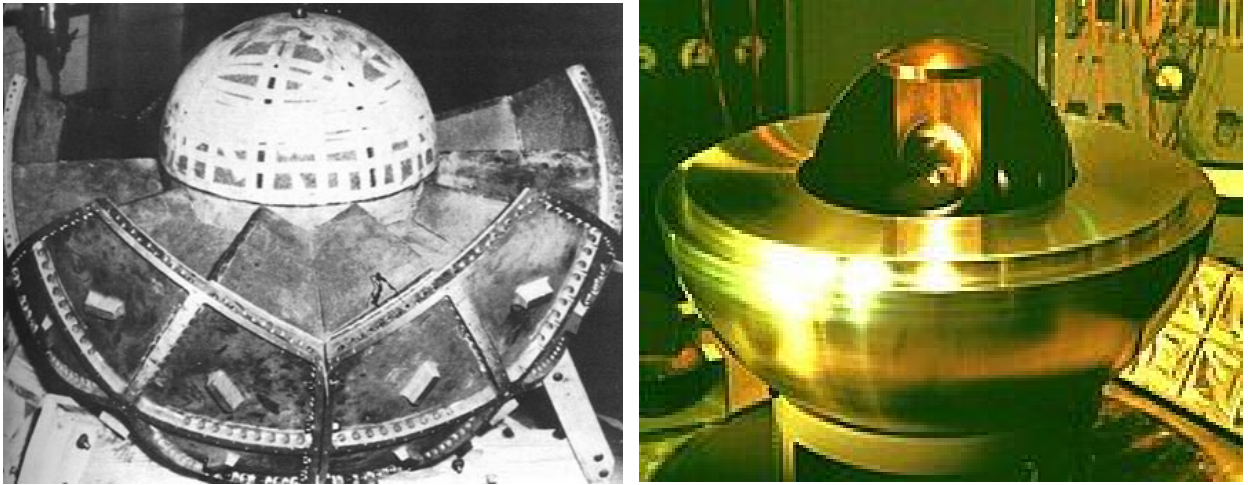

Figure 32. Museum mockups of the Trinity device showing the core, tamper and surrounding explosive lenses and their initiators.



Figure 33. Trinity device before installation of initiators.

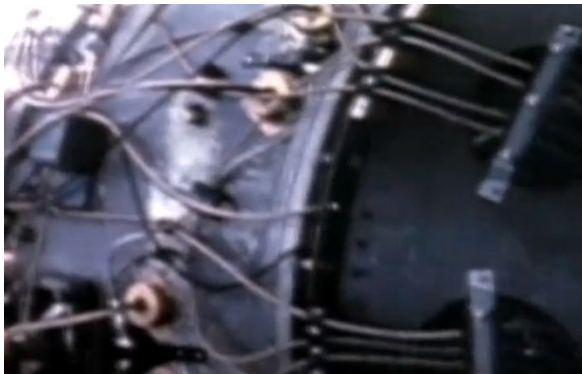
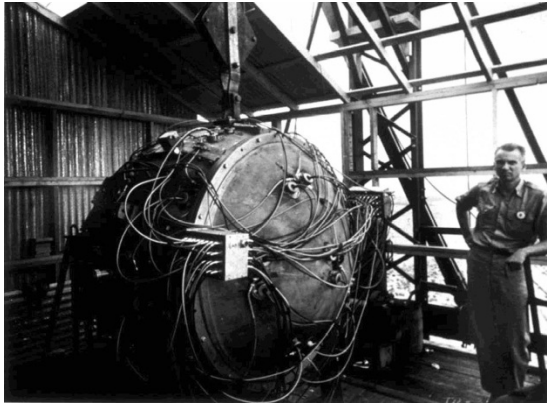



Figure 34. Photographs of the Trinity device on top and at bottom of its test tower showing the 32 initiators wiring.



Figure 35. Energy museum model of the Trinity device at Albuquerque, New Mexico.

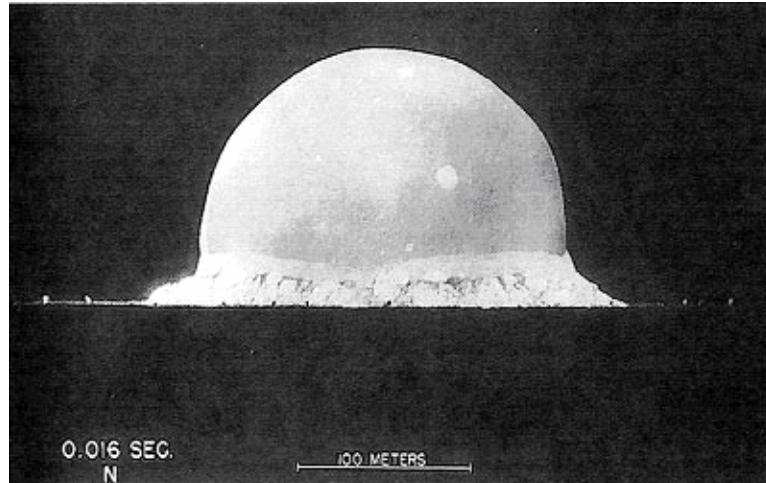

Figure 36. A photograph taken of the fireball and the horizontally expanding Mach stem generated by the Trinity test at 0.016 second into the explosion. Oppenheimer was Jewish and involved in studying or at least quoting Eastern religions. Right after the blast, he quoted from the Bhagavad Gita: “If the radiance of a thousand suns were to burst at once into the sky, that would be like the splendor of the Mighty One.”

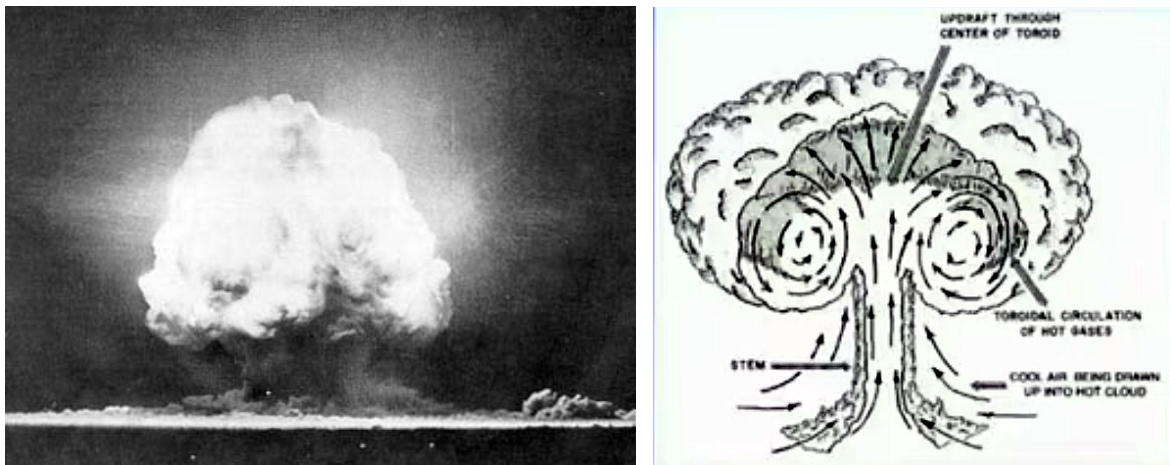

Figure 37. Mushroom cloud toroidal circulation from the Trinity test on July 16, 1945 at 5:29:45 am.

Because of uncertainties about the behavior of the implosion type device, it had to be tested for the first time at the Trinity Test Site on July 16, 1945 at 5:29:45 am. The test was conducted at Jornada del Muerto (In Spanish: Journey of Death), 100 miles south of Los Alamos in the Alamogordo desert of southern New Mexico. It was a plutonium implosion device placed at an optimal explosion height on a 100 foot tall tower, to maximize its shock wave or blast effects through the reinforcing interference of the incident and the reflected shock waves into the ground as a *horizontally* propagating Mach stem blast wave. The plutonium fission core was surrounded by an array of explosive lenses, in turn enclosed in a metal casing. Figure 32 shows a schematic, Fig. 33 shows a mockup, and Fig. 34 shows a photograph of the Trinity plutonium device, designated as “The Gadget” surrounded by the chemical explosive lenses' initiators.

1.10 NUCLEAR ENERGY RELEASE

The yield of the Trinity test was about 19 kilotons (kT) equivalent of the high explosive Tri-Nitro-Toluene (TNT). The site is now a historical site open to the public only once a year on the first Saturday of October each year. Figure 37 is a photograph taken of the fireball generated by the Trinity test, and its Mach stem at 0.016 second into the explosion.

An average value of the energy release per fission event in a fissile isotope such as U^{235} is 200 million electron volts (MeV). The MeV energy unit is equivalent to 1.6×10^{-6} ergs or 1.6×10^{-13} joules. The proportion in which this energy is distributed in a fission reaction is shown in Table 1.

Only a part of the energy is available in a nuclear explosion. This includes the kinetic energy in the fission products, most of the energy of the prompt gamma rays, which is converted into other forms of energy within the exploding weapon primarily ionization and x rays, and most of the neutron kinetic energy, but only a small fraction of the decay energy of the fission products. There is some contribution from the energy released in reactions in which neutrons are captured in the device's fragments. If we exclude the antineutrinos, whose 10 MeV are not available, and the delayed gamma rays (6 MeV) and the beta particles decay energy (7 MeV), and allow about 3 MeV for the neutron gamma reactions with the device fragments, about $200 - 10 - 6 - 7 + 3 = 180$ MeV of energy are immediately available per fission event.

Table 1. Apportionment of Energy Release from fission.

Distribution of Fission Energy	Energy [MeV]
Kinetic energy of fission fragments	165 ± 5
Prompt gamma rays energy	7 ± 1
Kinetic energy of fission neutrons	5 ± 0.5
Beta particles from fission products	7 ± 1
Delayed gamma rays from fission products	6 ± 1
Antineutrinos from fission products	10

Energy release per fission event	200 ± 6
Neutron- gamma reactions with device fragments	+3
Unavailable antineutrinos energy	-10
Unavailable fission products beta particles	-7
Unavailable fission products gamma rays	-6

Energy available in fission device	180

There are 6.02×10^{23} nuclei or Avogadro's number in a gram molecular weight or mole or 235 grams of U^{235} , or 239 grams of Pu^{239} . The explosive energy released by Tri-Nitro-Toluene $C_7H_5N_3O_6$ or TNT ranges from 900 to 1,100 calories per gram.

The energy release in Joules (J) from a molecule of TNT yields:

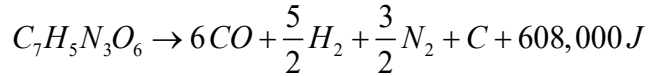

Some of the released carbon oxidizes into CO₂ yielding 393,510 J per mole of C. The hydrogen oxidizes into water releasing an extra 241,826 J per mole of H₂. The carbon monoxide oxidizes into CO₂ yielding 282,980 J per mole of CO. If all the carbon burns, and the nitrogen does not, this adds up to:

$$\begin{aligned} 608,800 + (6 \times 282,980) + \left(\frac{5}{2} \times 241,826\right) + 393,510 &= \\ 608,800 + 1,697,880 + 604,565 + 393,510 &= \\ 3,304,755J & \end{aligned}$$

The molecular weight of TNT is:

$$\begin{aligned} (7 \times 12.011) + (5 \times 1.0079) + (3 \times 14.0067) + (6 \times 15.994) &= \\ 84.077 + 5.0395 + 42.0201 + 95.964 &= \\ 227.1 \frac{gm}{mol} & \end{aligned}$$

The reported value of the heat of combustion for TNT is 3,305,000 J / mol, or:

$$\begin{aligned} 3,305,000 \frac{J}{mol} \frac{1}{227.1} \frac{mol}{gm} 10^9 \frac{gm}{kT} &= \\ 1.455 \times 10^{13} \frac{J}{kT} \frac{1}{4.184} \frac{calorie}{J} &= \\ 3.48 \times 10^{12} \frac{calorie}{kT} & \end{aligned}$$

A complication arises in that to optimize the energy of a blast, ammonium nitrate NH₄NO₃ (80 gm/mol) is added as an oxidizer to TNT actually yielding an explosive mixture designated as "Amatol." An optimal mixture is 21.3 percent TNT and 78.7 percent ammonium nitrate by weight yielding the reaction;

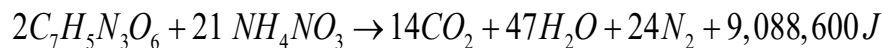

For practical dynamic considerations a mixture for the Amatol is 20 percent ammonium nitrate and 80 percent TNT.

The molecular weight of ammonium nitrate is:

$$\begin{aligned}
& (2 \times 14.0067) + (4 \times 1.0079) + (3 \times 15.994) = \\
& 28.013 + 4.0316 + 47.982 = \\
& 80.003 \frac{gm}{mol}
\end{aligned}$$

In the case of the Amatol mixture, the energy yield becomes:

$$\begin{aligned}
& 9,088,600 \frac{J}{mol} \frac{1}{(2 \times 227.1) + (21 \times 80.003)} \frac{mol}{gm} 10^9 \frac{gm}{kT} = \\
& 9,088,600 \frac{J}{mol} \frac{1}{(454.2 + 1680.063)} \frac{mol}{gm} 10^9 \frac{gm}{kT} = \\
& 9,088,600 \frac{J}{mol} \frac{1}{2,134.263} \frac{mol}{gm} 10^9 \frac{gm}{kT} = \\
& 4.2584 \times 10^{12} \frac{J}{kT} \frac{1}{4.184} \frac{calorie}{J} = \\
& 1.018 \times 10^{12} \frac{calorie}{kT}
\end{aligned}$$

The kiloton could be considered as the short kiloton corresponding to 2×10^6 pounds, the metric kiloton would be equal to 2.205×10^6 pounds, or the long kiloton equal to 2.24×10^6 pounds.

To avoid ambiguity, the energy released from one thousand tons or 1 kiloton (kT) of TNT is defined to be 10^{12} calories. This is equivalent to 1 short kT of TNT if the energy release is 1,102 calories per gram, and to 1 long kT if the energy release is 984 calories per gram of TNT. This resulted in the published energy equivalences shown in Table 2.

Table 2. Energy equivalence of 1 kt of TNT.

Device Energy Release	Energy Equivalents
1 kT of TNT =	10^{12} calories
	2.6×10^{25} MeV
	4.184×10^{19} ergs
	4.184×10^{12} joules
	1.16×10^6 kW.hrs
	3.97×10^9 BTUs
	fission of 56.8 grams of fissile nuclei
	fission of 2.00 ounces of fissile nuclei
	Fission of 1.45×10^{23} fissile nuclei

The number of fissions that would release the equivalent of 1 kT of TNT can be estimated from:

$$\begin{aligned}
 1 \text{ kT TNT} &= 10^{12} \text{ calories} \times 4.184 \frac{\text{Joule}}{\text{calorie}} \times \frac{1}{1.60207 \times 10^{-19} \text{ Joule}} \frac{\text{eV}}{\text{Joule}} \times 10^{-6} \frac{\text{MeV}}{\text{eV}} \times \frac{1 \text{ fission}}{180 \text{ MeV}} \\
 &= 1.45 \times 10^{23} \text{ nuclei}
 \end{aligned}$$

where we used the average extractable energy of $200 - 10 - 6 - 7 + 3 = 180$ MeV per fission event, excluding the antineutrinos and the delayed beta gamma rays whose energies cannot be extracted, but allowing for about 3 MeV for the (n, γ) capture reactions with the device debris..

Using Avogadro's law:

$$N = \frac{g}{M} A_v \text{ nuclei} \quad (10)$$

where: g is the mass in grams,

M is the atomic mass in amus,

$$A_v = 0.6 \times 10^{24} \frac{\text{nuclei}}{\text{mole}},$$

the mass of fissile material resulting from the fissioning of N fissile nuclei is:

$$g = \frac{N.M}{A_v} \text{ gm} \quad (11)$$

EXAMPLE

The mass of U^{235} nuclei leading to the release of 1 kT of equivalent TNT excluding the antineutrinos and delayed gamma rays is:

$$\begin{aligned}
 g &= \frac{N.M}{A_v} \text{ gm} \\
 &= \frac{1.45 \times 10^{23} \times 235}{0.6 \times 10^{24}} \text{ gm} \\
 &= 56.8 \text{ gm} \\
 &= 56.8 \text{ gm} \times 0.03527 \frac{\text{ounce}}{\text{gm}} \\
 &= 2.00 \text{ ounces}
 \end{aligned}$$

1.11 DISTINCTION BETWEEN A NUCLEAR REACTOR AND AN EXPLOSIVE DEVICE

MULTIPLICATION FACTOR AND CRITICALITY

We try to identify and clarify the difference between a nuclear reactor and an explosive device in terms of the energy release as a function of the number of neutron generations in the fission process. Let us define:

- ν : the average number of neutrons released per fission event,
- a : the average number of neutrons lost by absorption in the active material per generation,
- ℓ : the average number of leakage neutrons released from the active geometry per generation.

We can define a multiplication factor k as:

$$k = \nu - a - \ell \quad (12)$$

Three situations present themselves according to the value of the multiplication factor k :

$$\begin{aligned} k=1 &\Rightarrow \text{a critical system,} \\ k>1 &\Rightarrow \text{a supercritical system,} \\ k<1 &\Rightarrow \text{a subcritical system.} \end{aligned} \quad (13)$$

EXPONENTIAL NEUTRON GENERATIONS GROWTH MODEL

The number of fissioned nuclei in 1 kT of TNT equivalent to the fission of 56.8 gms of U^{235} from Table 2 and Eqn. 11 is:

$$N = \frac{56.8}{235} 0.6 \times 10^{24} = 1.45 \times 10^{23} \text{ nuclei.}$$

If N is the number of neutrons present at any instant, from Eqn. 12, the number of neutrons in the next generation will be:

$$Nk = N(\nu - a - \ell)$$

The increase in the number of neutrons from one generation to the next becomes:

$$\begin{aligned} dN &= Nk - N \\ &= N(k - 1) \\ &= N(\nu - a - \ell - 1) \end{aligned}$$

Let the generation time be denoted by τ . Thus we can write the rate of neutrons increase as:

$$\frac{dN}{dt} = \frac{N(k - 1)}{\tau} \quad (14)$$

Separating the variables followed by limit integration, assuming that k and τ are constant, yields:

$$\int_{N_0}^{N(t)} \frac{dN(t)}{N} = \frac{(k-1)}{\tau} \int_0^t dt$$

$$\ln \frac{N(t)}{N_0} = \frac{(k-1)}{\tau} t \quad (15)$$

$$N(t) = N_0 e^{\frac{+(k-1)t}{\tau}}$$

by taking the exponential of the natural logarithm function.

This shows that the neutron generation undergoes an exponential growth as a function of time.

We can express the number of neutrons as a function of the number of generations as:

$$n = \frac{t}{\tau} \quad (16)$$

Substituting from Eqn. 16 into Eqn. 15, results in a change of variables from t to n as:

$$N(n) = N_0 e^{+(k-1)n} \quad (17)$$

EXAMPLE

Adopting the numerical values: $v = 2.5$, $a = 0.5$, $\ell = 0$, $k = 2.5 - 0.5 - 0.0 = 2$, then:

$$N(n) = N_0 e^{+n} \quad (18)$$

This assumes no leakage of the neutrons. The number of generations in which 0.1 kT of TNT equivalent of energy corresponds to the fissions of $0.1 \times 1.45 \times 10^{23} = 1.45 \times 10^{22}$ nuclei, and the release of 100 kT of TNT equivalent corresponds to the fissions of $100 \times 1.45 \times 10^{23} = 1.45 \times 10^{25}$ nuclei. If we further assume that the chain reaction is initiated by a single neutron, then $N_0 = 1$, and thus:

$$N = e^{+n} \quad (19)$$

Taking the natural logarithm of both sides we get:

$$\ln N = \ln e^n = n \ln e = n$$

We can thus construct Table 3 relating the total energy release to number of neutron generations n .

Table 3. Energy release as a function of the number of neutron generations n.

Energy Release [kT TNT]	Number of fissions N	Number of generations n = ln N
0.1	1.45×10^{22}	51.03
1.0	1.45×10^{23}	53.33
10	1.45×10^{24}	55.63
100	1.45×10^{25}	57.93

Hence the release of 1 kT of TNT equivalent requires the confinement of the fission reaction for at least 53 neutron generations, thus in nuclear devices the reaction must be confined by use of a tamper.

In a nuclear reactor no tamper is used, hence it is impossible to confine a supercritical system for more than a few neutrons generations, since the heat release would disassemble, through melting followed by vaporization, the configuration into a subcritical one, shutting down the chain reaction.

The following observations can be made:

1. There is a need for a very large number of 51 neutron generations to release a mere 0.1 kT of TNT equivalent.
2. Most of the energy release:

$$\frac{100 - 0.1}{100} = \frac{99.9}{100} = 0.999,$$

or 99.9 percent is released in the last $58 - 51 = 7$ generations in a short period of approximately 7×10^{-8} sec = 0.07 μ sec, or less than a tenth of a microsecond.

3. Nuclear explosives are “tamped” inertially with a high strength high-density “blanket” material such as Be, BeO, W, Pb, Ta, Au, U^{238} or U^{235} (for dual-cores) to increase the inertial confinement time and obtain fissions and energy release from the latest number of generations.

4. Nuclear reactors are not tamped. The heat release will thus melt then vaporize any supercritical configuration and disperse it. Dispersion restores subcriticality of the configuration with stoppage of the energy release.

5. Thermal reactors cannot explode like nuclear explosive devices, since they are constructed differently.

6. The worst that can happen in a fast reactor accident is compaction of the core to supercriticality with a substantial nuclear energy release, but not a complete explosion, since the dispersal of the untamped material would lead to subcriticality and a rapid shutdown of the chain reaction.

OTHER TECHNICAL DIFFERENCES

To initiate a nuclear explosion in a nuclear device, the fissile materials such as U^{235} or Pu^{239} , or a combination of them in a dual core configuration, are brought together very rapidly and then kept together for a long enough time, such that a significant fraction of their nuclei undergo the fission process. The fissile components of the device are driven together with explosive force

producing rapid increases in the reactivity of the system way beyond the neutrons prompt critical state. This necessitates the use of Pu²³⁹ and/or U²³⁵ with a high enrichment in the fissile isotopes because the other isotopes act as a sink for the fast neutrons needed for the process. Under these circumstances, the fissions are due to fast neutrons, the time between the neutron generations is very short, no delayed neutrons exist, high enrichments are used, and massive amounts of energy are released before the material has time to blow itself apart, overcoming the inertial resistance to its expansion by the surrounding tamper, terminating the fission reaction.

In a thermal reactor, on the other hand, the situation is totally different. The fuel is low enriched uranium with a large proportion of U²³⁸, which absorbs neutrons, and a small proportion of U²³⁵ and Pu²³⁹ at only 3-5 percent. The fuel is also surrounded by a moderator that slows down the energy of the neutrons produced. In a power surge, even if a prompt neutrons critical state is attained, the presence of the U²³⁸ damps down the increase in reactivity by absorbing the neutrons as they are slowed down through the nuclear negative feedback mechanism of “Doppler resonance broadening.”

This inherent negative feedback Doppler coefficient of reactivity is a safety characteristic of all commercial nuclear plants and research reactors and describes the fact that as the fuel gets hotter it gets less effective at using neutrons to induce fission and produce power causing the reactor’s reactivity to fall. The nuclear reactors’ Doppler coefficient is always negative, causing its reactivity to decrease as its temperature increases.

In addition, the majority of fissions in nuclear reactors are caused by slow neutrons for which the time between successive fissions is longer than in the case with fast neutrons. The effective neutron lifetime and hence the reactor period is increased even more by the presence of the delayed neutrons released from the decay of the fission products. The end result is that the energy released by a power surge will disrupt the fuel and terminate the chain reaction long before the reactivity reaches the very high levels needed in a nuclear device. The energy released in a power surge, including fast reactors, would be far lower: by as much as 100 million times less in magnitude than in a nuclear device.

1.12 NUCLEAR DEVICES USE IN WAR

INTRODUCTION

The decision was reached to use the atomic bomb against Japan on two targets without prior demonstration or warning. The argument that won the debate, concerning prior demonstration, was that it would save soldiers’ lives on both sides, as well as civilians on the Japanese side, who would have otherwise to incur heavy losses as collateral damage in a conventional invasion of the Japanese islands. The large human losses on both the American and Japanese sides in the invasion of the Japanese island of Okinawa supported this fear. There were opposing rumblings and accusations to the effect that the decision was based on the political need to use the weapons to justify the effort and expenses of building them.

What is remarkable is that the two approaches that were followed to construct the bomb, the uranium²³⁵ enrichment approach as well as the plutonium²³⁹ breeding approach, both succeeded. Figure 39 shows a replica of the gun barrel design using U²³⁵ as a fissile material, designated as Little Boy. Figure 41 shows the actual Fat Man Implosion device employing Pu²³⁹ as a fissile material.

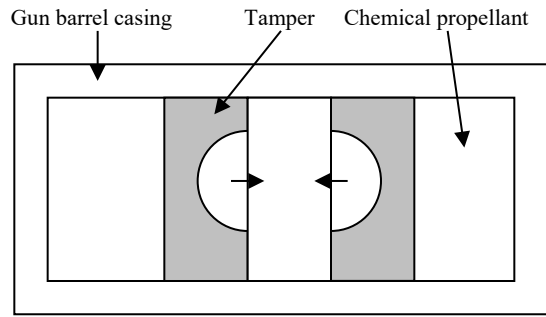

Accelerated two hemispheres configuration

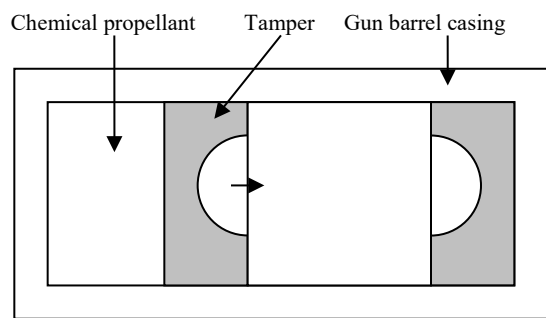

Single accelerated hemisphere configuration

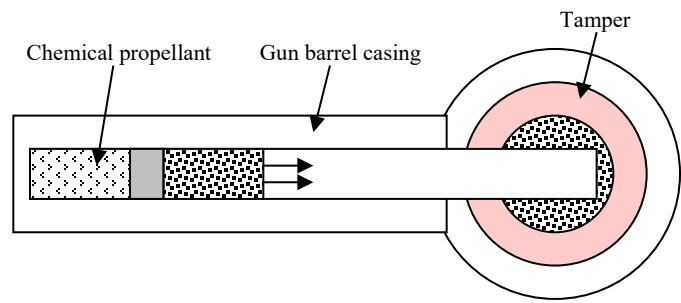

Accelerated plug configuration

Figure 38. Gun barrel configurations could contain two subcritical masses of highly enriched U^{235} assembled into one supercritical mass.

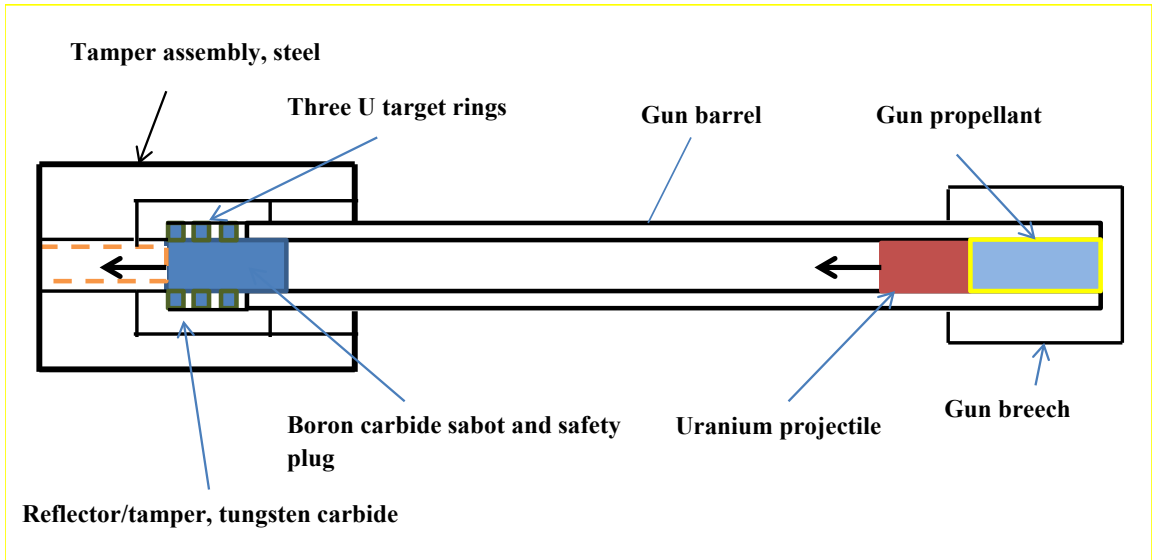
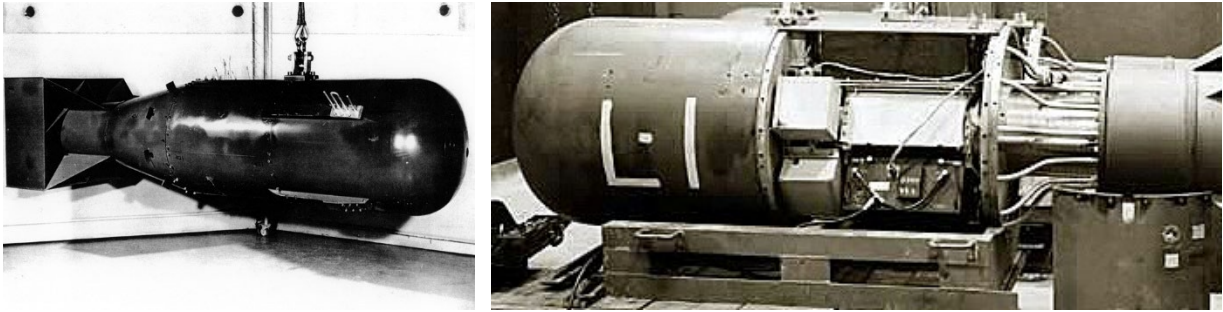
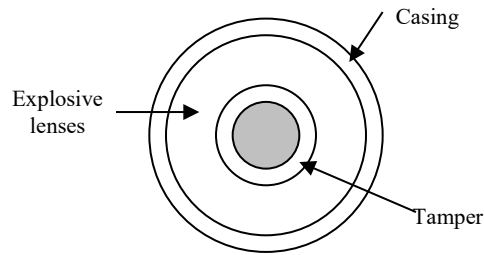

Figure 39. A replica, cutout and schematic of the Little Boy large metallic gun barrel device dropped on Hiroshima. “After the war ended, it was not expected that the inefficient Little Boy design would ever again be required, and many plans and diagrams were destroyed.” “There were several reasons for not testing a Little Boy type of device. Primarily, there was little uranium²³⁵ as compared with the relatively large amount of plutonium which, it was expected, could be produced by the Hanford Site reactors. Additionally, the weapon design was simple enough that it was only deemed necessary to do laboratory tests with the gun-type assembly. Unlike the implosion design, which required sophisticated coordination of shaped explosive charges, the gun-type design was considered almost certain to work.” The Little Boy bomb design had 64kg of Uranium enriched to an average of 80%. The USA built 26 of them. That was the first design that was "mass produced".

Natural uranium has a 0.72% of fissile uranium²³⁵. Reactor designs use 3-5% enriched Uranium²³⁵. You have to extract that 0.72 from uranium, depleting to 0.25% of it in the process. For every kg of reactor fuel at 3% enrichment, one ends up with about 4 kgs of DU. For weapons grade uranium, every 1 kg of 80% pure uranium leaves you with about 104 kg of DU. The Little Boy bomb design built in Hiroshima had 64 kgs of Uranium enriched to an average of 80%.

The Little Boy gun-barrel device is reported to have been 304 cm long and 71 cm in diameter. It was exploded at a height of 570 meters at 08:15 hour on August 6, 1945 generating about 15 kT of TNT equivalent of yield. It had a low efficiency and is reported to have fissioned

only 1.5 lbs of its uranium content. The overall device weighed 4-5 metric tonnes. It was made of 64 kgs of uranium with an enrichment of 80 percent or 51 kgs of U^{235} . At 50 kgs as critical mass, this corresponds to 7,000 kgs equivalent of natural uranium. This corresponds to the critical mass of an uncompressed bare unreflected sphere of U^{235} . Sophisticated methods of uranium storage and controlled implosion have reduced the critical mass by a factor of 2-3. The hazard of uncontrolled explosions limits the amount of U^{235} content of a modern warhead with 5-10 times the yield of Little Boy. The arming device consisted of three U^{235} rings.



Solid core implosion

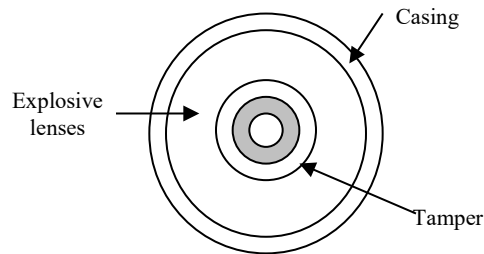

Spherical shell implosion

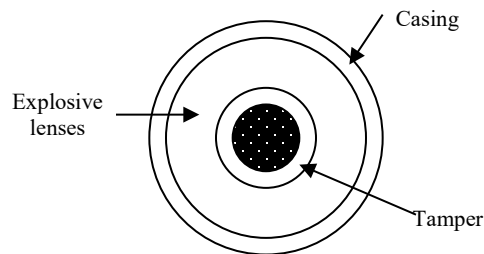

Porous core implosion

Figure 40. The Implosion process configurations use solid cores, spherical shells or porous cores. With fast compression and a tamper, modern weapons are reported to use 15-20 kgs of Weapons Grade Uranium (WGU) instead of the about 50 kgs bare critical mass of U^{235} .

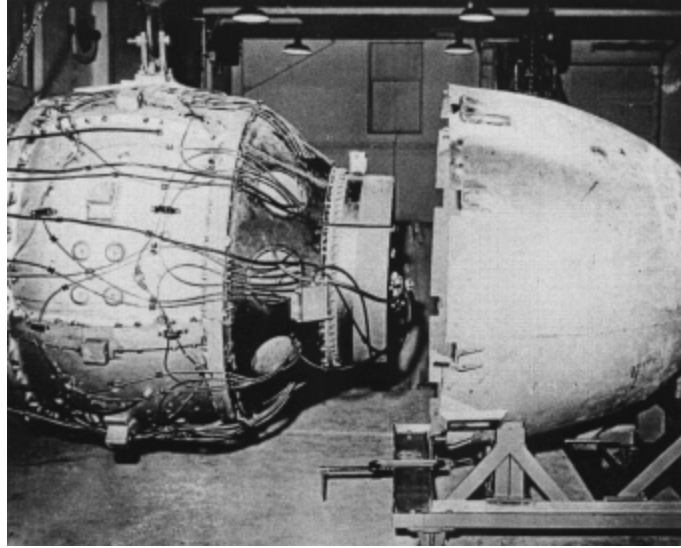

Figure 41. Disassembled Fat Man Implosion device dropped on Nagasaki. Fat Man used 6.4 kgs of Pu239 with a yield of 21 kT of TNT equivalent, whereas the less efficient Little Boy device used 64 kgs of U235 with a yield of 15 kT of TNT equivalent.

The Fat Man implosion device was exploded at 503 meters height at 10:58 hour on August 9, 1945. It was 325 cm long and 154 cm in diameter. It generated 22 kT of yield mostly from plutonium. It weighed 4-5 metric tonnes of which the nonfissioning assembly material constituted a thick blanket surrounding the fission core.

HIROSHIMA BOMBING

Colonel Paul Tibbets lead the 509th Composite Bomb group and prepared at Wendover air base in Utah for the bomb dropping. The bombers had to train on bomb dropping procedures, plane maneuvers and tactics that would allow the bombers to mitigate the effects of the released gamma rays traveling at the speed of light on the bomber's crew, followed by the neutrons, and escape the blast wave from the explosion.

On August 1, 1945, B-29 bombers arrived on the coral island of Tinian in the Pacific Ocean, 1,500 miles south of Japan. The USS Indianapolis heavy cruiser had delivered the bomb components. The war was still continuing, the Indianapolis was later sunk by a Japanese submarine on its trip back from its secret mission.

On August 6, 1945, the Enola Gay B-29 bomber, on exhibit at the Smithsonian Museum in Washington D.C., dropped a gun barrel bomb design using U²³⁵, designated as Little Boy, on Hiroshima, Japan at 8:16:02 am. It measured 28 inches in diameter and 129 inches in length. It weighed 9,000 pounds. The yield of the device was 12.5 kT of TNT equivalent.

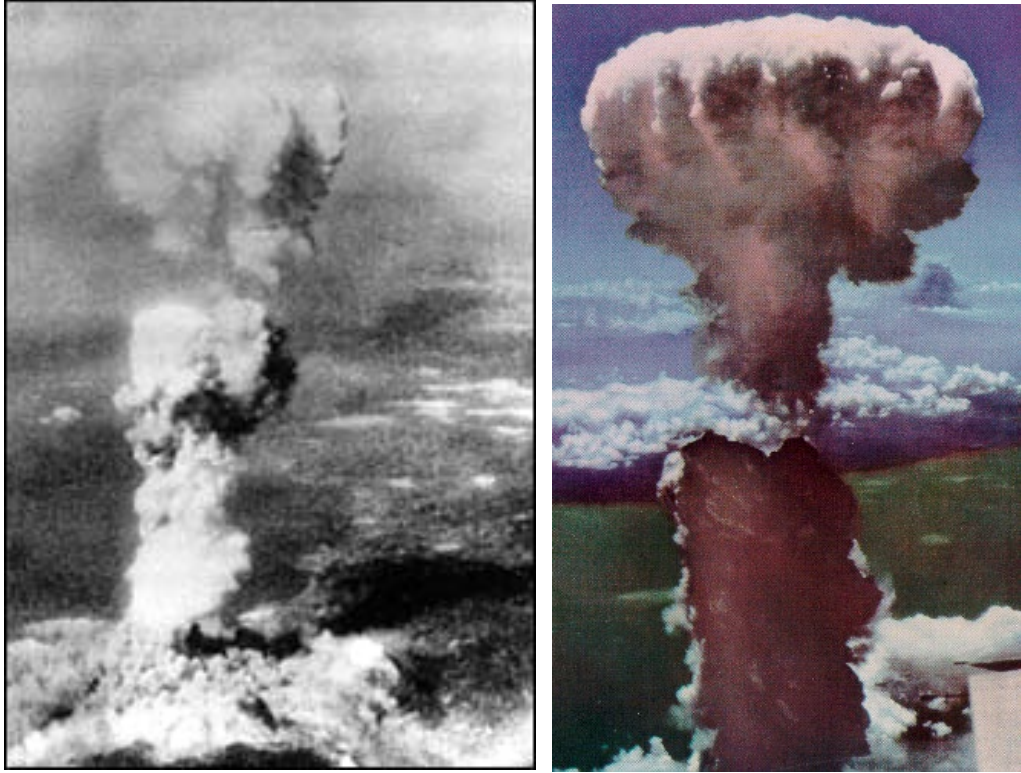

Figure 42. The mushroom cloud that rose from the Little Boy Hiroshima device's fireball on August 6, 1945 (left), and the one over Nagasaki, August 9, 1945 (right).



Figure 43. The Little Boy device being loaded into the Enola Gay, named after the pilot's mother, B-29 delivery bomber.

Most of the city was destroyed, and 90 percent of the people in a ½ km or 0.3 mile radius perished. By 1946, it is estimated that between 80,000 and 140,000 people had died from the immediate after-effects and 100,000 more were injured. The radiation dose resulted primarily from fast neutrons.



Figure 44. Survivors, hibakusha. Burn victims from the Hiroshima explosion. Burns are more prominent where the x rays were preferentially absorbed in the dark clothing areas.

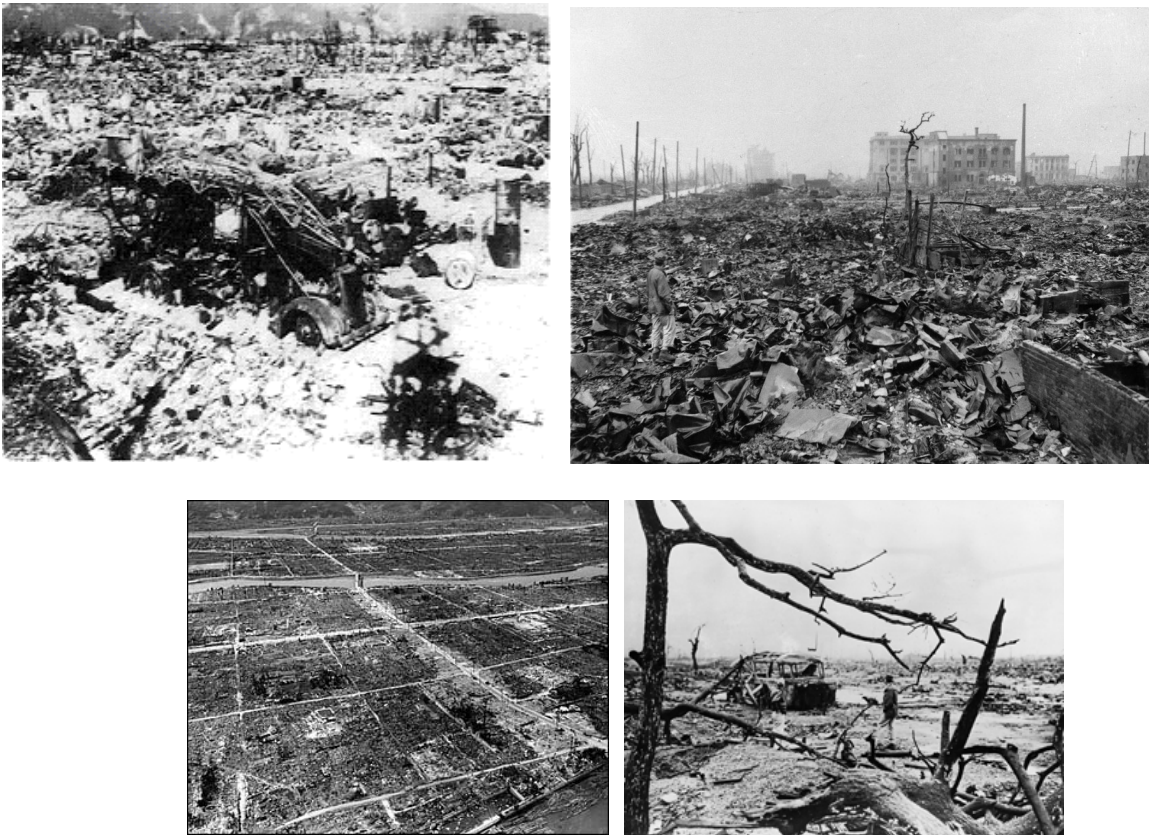

Figure 45. The effects of the Hiroshima weapon 4,000 feet from “ground zero.” A fire station and its equipment are shown.



Figure 46. Hiroshima's most famous ruin from the atomic bombing is the dome in the city's Peace Memorial Park. The effects of the Hiroshima weapon showing the Genbaku building a concrete movie theatre remaining skeletal structure; now preserved as a "Peace Dome" memorial. A Unesco World Heritage site, it has undergone reinforcement work to make it more earthquake resistant.





Figure 47. Hiroshima ground zero aftermath effects.

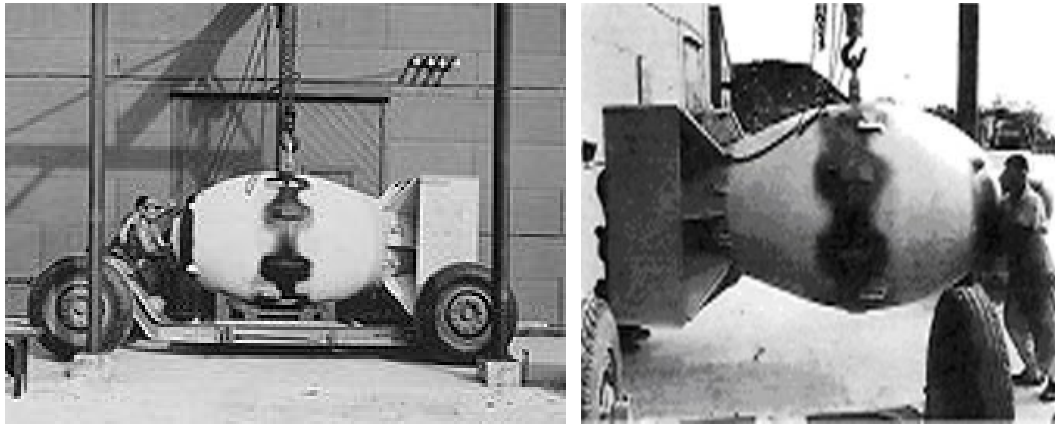

Figure 48. The B-29 bomber Bockscar dropped the Nagasaki plutonium Fat Man device shown at the Tinian Island.



Figure 49. Aftermath of the bombing and ensuing fire-storm at Nagasaki.



Figure 50. Catholic cathedral (left) and Buddhist temple (right) explosion remnants at Nagasaki.



Figure 51. Nagasaki ground blast effects.

NAGASAKI BOMBING

On August 9, 1945, the Bockscar B-29 bomber dropped an implosion device using Pu^{239} , designated as Fat Man on Nagasaki, Japan. The latter measured 60 inches in diameter, and was 128 inches long. It weighed about 10,000 pounds. About 74,000 persons perished and 75,000 were injured out of the 286,000 inhabitants of the city. The device fell off-target and few military personnel were affected. By some counts, more American Prisoners of War (POWs) died from the bombing of Nagasaki than Japanese military personnel. A hospital and an American mission college were destroyed, but to spare them would have also meant sparing some munitions plants.

Many who supported the first atomic bombing of Hiroshima expressed misgivings about the Nagasaki bombing because of the failure of USA to give the Japanese a few days to consider surrender after the first blast. The Soviet Union took advantage of the situation and suddenly declared war on Japan. Kurt Vonnegut, Jr., once said in an interview that the “nastiest act by this country, after human slavery, was the bombing of Nagasaki.” Telford Taylor, the chief prosecutor at the Nuremberg trials, called it a “war crime.”

Radiation sickness caused latent deaths. At one hospital, 200 of 343 admitted patients succumbed to it. A photograph of a survivor burn victim in Fig. 43 shows the effect of x-ray absorption at the dark parts of the clothing. The hilly nature of the landscape at Nagasaki, compared with the flat one at Hiroshima, resulted in a lower number of victims despite the larger released explosive yield. The radiation dose was primarily from x and gamma rays. The weapon's yield was 22 kT of TNT equivalent.

Figure 42 shows the mushroom clouds that resulted from the Hiroshima and Nagasaki devices fireballs, with the buildings of the cities appearing at the bottom of the photograph. Figures 40, 41 show its effects at “ground zero” directly under the explosion, and Figs. 47-49 show the blast effects at the second bomb explosion at Nagasaki.

Tokyo was fire-bombed March 9, 1945 killing around 100,000 people. From March to July 1945, 66 other Japanese cities were fire-bombed, causing another half a million deaths.

Table 4 gives estimates of the casualties caused by the atomic blasts at Hiroshima and Nagasaki compared with those from the fire-storm bombing of Tokyo with conventional and incendiary explosives on March 9, 1945, and with the average of 93 aerial attacks on other Japanese cities. The fire-bombing evidently caused higher casualties. However, the higher mortality and casualty rates per square mile destroyed by the atomic devices is also clearly apparent.

Table 4. Nuclear device effects ranges [m].

Effect	1kT TNT	10 kT TNT	100kT TNT
Fireball	10	200	500
Shock / Blast wave [5 psi overpressure]	500	1,000	2,000
Prompt radiation dose [500 rem / cSv]	1,100	1,500	1,500
Heat flux, 4-5 [calories/cm ²]	600	1,700	4,700

The effects of nuclear devices scale as a function of the yield Y in kT of TNT equivalent:

$$\text{Radiation radius : } R \sim Y^{0.19} [m]$$

$$\text{Blast / shock wave radius : } R \sim Y^{0.33} [m]$$

$$\text{Thermal infrared radius : } R \sim Y^{0.41} [m]$$

For small devices radiation effects are predominant, for large devices, it is the heat flux and the blast.

Table 5. Casualties comparison between conventional and nuclear explosives.

	Hiroshima	Nagasaki	Tokyo 1,667 tons TNT and incendiary	Average of 93 attacks 1,129 tons TNT and incendiary
Population per square mile	35,000	65,000	130,000	-
Square miles destroyed	4.7	1.8	15.8	1.8
Killed and missing	70,000, direct 140,000, long term	36,000	83,000	1,850
Injured	35,000	40,000	102,000	1,830
Mortality per square mile destroyed	15,000	20,000	5,200	1,000
Casualties per square mile destroyed	30,000	42,000	11,800	2,000

Strategic bombardment as stated by military analyst Liddel Hart was: "the most uncivilized method of warfare the world has known since the Mongol devastations." Earlier, Tokyo was

firebombed with 1,667 tons of TNT explosives and incendiary munitions and London was subjected to 57 consecutive nights of bombings by the German Luftwaffe.

The “Dresden Commission of Historians for the Ascertainment of the Number of Victims of the Air Raids on the City of Dresden on 13-14 February 1945” has provisionally estimated the likely death toll at around 18,000 and no more than 25,000. Dresden was a German city of 3/4 of a million people, its population further swollen by hordes of anonymous refugees from the Eastern Front. Its historic heart was destroyed in one apocalyptic night by aircraft armed with more than 4,500 tons of high explosive and incendiary bombs. The devastated area amounted to around 13 square miles or 34 square kilometers. “The asphalt of the street melted and people sank into the molten asphalt as if it were a river.” “It took seven years just to clear the rubble.”

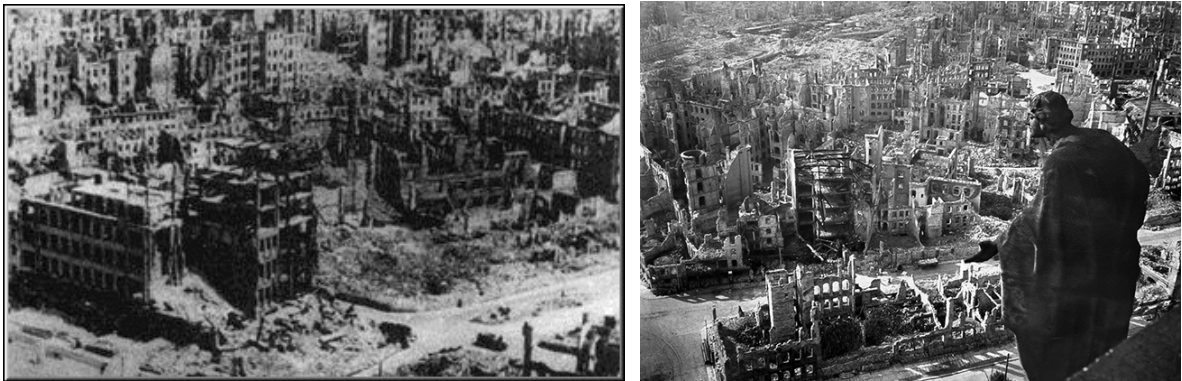

Figure 52. Effect of fire-storm from incendiary bombing on February 13 – 15, 1945, at the city of Dresden, Germany, resulted in 600,000 victims.

Dresden was an important industrial center with over 100 factories and industrial enterprises that employed 50,000 workers. Dresden was also a key junction in Germany’s railway system, with rail lines radiating from the city in all directions. The USA policy was precision day-bombing factories and refineries. The British favored indiscriminate bombing cities at night to terrorize the civilian population. The American bombing saved more Allied soldiers' lives ultimately because it takes time to rebuild a factory and without oil, even the best army is mobility limited:

“The ancient cultural center of Dresden, a city rich in 18th century architecture, was not a military or industrial target so it had little or no anti-aircraft weapons as an air attack was not anticipated. As the war was winding down, Russian forces were sweeping across Germany from the East and Dresden’s normal population of 600,000 had recently swollen an additional 300,000 to 500,000 with refugees fleeing the Russian advance, now only 70 miles away.

Dresden had no air raid shelters; every public building was crowded with refugees, mostly women and children, and many were camped in the streets.

The first attack came at night...about 9:30 p.m. ... as the British Royal Air Force sent in more than 800 heavy bombers. All planes returned to base safely. And while heavy black smoke covered the city next day, an armada of bombers went back to give it everything they had - 1,350 Fortresses and Liberators. The following

day, 1,100 U.S. 8th Army Air Force bombers hit the devastated Dresden a third time.

Within 36 hours, perhaps, 250,000 people were killed...funeral piles of 500 bodies each burned for days.”

On March 9, 1945, 334 USA air force B-29 superfortress bombers dropped 2,000 tons of napalm and magnesium incendiaries on the timber and paper houses of Asakusa. Officially, 83,793 Japanese were killed, 40,918 injured and 265,171 buildings destroyed.

USA commander Jimmy Doolittle, who against Churchill's proposed Operation Thunderclap that aimed to kill 275,000 Berliners in a single 2,000-plane raid scheduled for August 1944. It did not take place. Winston Churchill called on USA President Franklin D Roosevelt to speed up production of a promised 500,000 top-secret "N-bombs" filled with anthrax, developed at Dugway Proving Grounds in Utah- to be dropped on Berlin and five other German cities. USA's war secretary Henry Stimson said he did not want "the United States to get the reputation of outdoing Hitler in atrocities". By the time Germany surrendered in May 1945, USA and British raids had destroyed 45% of German housing. After the war, about 1.5 million Germans died from hunger and disease in prison camps, and 375 thousand died in Russian camps.

YALTA AND POTSDAM MEETINGS

It was at a meeting at Yalta in Crimea in February of 1945 that the whole of Europe was divided into Soviet Union/American/British and French occupation zones near the end of World War II. Victory V-day was in May 1945. After the Yalta Conference of February 1945, Stalin, Churchill, and USA President Franklin D. Roosevelt had agreed to meet following the surrender of Germany to determine the postwar borders in Europe. Germany surrendered on May 8, 1945, and the Allied leaders agreed to meet over the summer at Potsdam to continue the discussions that had begun at Yalta. It was mutually agreed that Berlin would be divided into two zones between the USA and the Soviets, while Austria was divided into four zones. The city of Vienna itself was also divided into four different sections with representatives of all powers driving around in Jeeps. Only the British and the Americans could converse. Going from one part of Vienna to another required a passport. The British/Americans and French eventually left Vienna but the Soviets stayed until 1952.

President Roosevelt died in April 1945. Another meeting took place at Potsdam with President Truman replacing him, which became a rather hostile meeting. The Big Three—Soviet leader Joseph Stalin, British Prime Minister Winston Churchill (replaced on July 26 by Prime Minister Clement Attlee), and USA President Harry Truman—met in Potsdam, Germany, from July 17 to August 2, 1945, to negotiate terms for the end of World War II. According to the Protocol of the Conference, there was to be “a complete disarmament and demilitarization of Germany”; all aspects of German industry that could be utilized for military purposes were to be dismantled; all German military and paramilitary forces were to be eliminated; and the production of all military hardware in Germany was forbidden.

The Potsdam Conference is best known for President Truman’s July 24, 1945 conversation with Stalin, during which time the President informed the Soviet leader that the United States had successfully detonated the first atomic bomb on July 16, 1945. Historians have often interpreted Truman’s somewhat firm stance during negotiations to the U.S. negotiating team’s belief that U.S. nuclear capability would enhance its bargaining power. Stalin, however, was already well-

informed about the U.S. nuclear program thanks to the Soviet intelligence network; so he also held firm in his positions.

President Roosevelt had wanted Soviet help in Japan while President Truman did not. President Truman may have dropped the nuclear bombs on Hiroshima and Nagasaki solely to show the Soviets what the USA possessed and was willing to use: a warning not to meddle in the Far East.

For the Americans population the bombings were sold as a means to shorten the war and prevent unnecessary American and Japanese deaths. The reality was that for many months the Japanese were seeking a negotiated surrender to the USA, which insisted on an unconditional one.

1.13 NAVAL TRAGEDY OF THE USS INDIANAPOLIS CRUISER

The USS Portland-class heavy cruiser Indianapolis CA-35 had sailed 5,000 miles across the Pacific Ocean in just 10 days to deliver the U²³⁵ atomic device components to the Tinian Island on July 27, 1945, less than a week before the nuclear bomb it helped to assemble was dropped on Hiroshima. It had been repaired in a dry dock after being attacked and suffering a near fatal hit on March 31, 1945 by a Japanese army Oscar airplane on a Kamikaze, Divine Wind, mission on its naval strafing mission prior to the invasion of the Japanese island of Okinawa, 400 miles from the Japanese mainland.

Being on a secret mission, the crew did not know the nature of its cargo. It sailed alone and was denied an escort by a destroyer equipped to detect and fight the Japanese submarines. At the time of her sinking, the ship's commanding officer Captain Charles McVay III, son of an admiral, and with a promising career, was blamed for her loss and the loss in its crew. However, information was withheld from Captain Charles McVay III about submarine activity in the area on its way to the Philippines, and especially about how the Navy policies at the time precluded the Navy from even realizing that the ship was lost for days. A ship had been recently sunk by a Japanese submarine on the same route.

On July 30, 1945, the Indianapolis in the Philippine Sea between Guam and Leyte was intercepted and hit by two torpedoes out of a fanning salvo of six torpedoes at 12:05 am, one blowing off most of her bow, where the officers slept. About 900 of the 1,196 sailors on board initially survived its sinking, which lasted 12 minutes. The rest were trapped inside the sinking hull. However, only 316 or $316 / 1196 = 0.264$ or 26 percent of its crew would ultimately survive the horrors of hallucination from dehydration, heat and terrorizing attacks by dozens of sharks. The human body cannot endure more than three days without fresh water. Drinking sea water out of thirst caused further dehydration and hallucinations. Water jackets were designed to last only 72 hours. An account of their tragic ordeal over 4 ½ days and 5 nights was described in the Hollywood movie: "Jaws."

The Indianapolis did not have sonar to detect submarines. The captain, Charles McVay, had asked for an escort, but his request was turned down. The US Navy also failed to pass on information that Japanese submarines were still active in the area. The Indianapolis was all alone in the Pacific Ocean when it sank. Although the Indianapolis had sent several SOS signals before it sank, somehow the messages were not taken seriously by the Navy. Nor was much notice taken when the ship failed to arrive on time.

The Indianapolis was sunk by the Japanese submarine I-58 under Lt. Cdr. Mochitsura Hashimoto, who was later promoted to Commander for the same attack, in the Philippines Sea. This submarine had not scored any hits since the beginning of the war. USA Navy Intelligence

intercepted a Japanese radio message about the sinking of a large ship, but ignored it, reasoning that it was a trap to attract rescue ships into an ambush. The survivors were not missed until August 2, 1945; four days later. It was planned that the Indianapolis would return to Leyte on July 31, 1945. A reconnaissance aircraft on a routine patrol flight accidentally spotted the survivors in the water on August 2, 1945. Rescue operations started on August 3rd but did not complete until August 8, fully 9 days after the sinking. Three days later on August 6, 1945, the Indianapolis' cargo reaches its fateful destination on Hiroshima.

The ship's commanding officer, Capt. Charles McVay III survived, only to commit suicide with his service handgun in 1968 being upset about receiving hate mail.



Figure 53. The Portland-class heavy cruiser USS CA-35 Indianapolis, or The Indy, off Mare Island shipyard on July 10, 1945 after its repair from a Kamikaze attack off the island of Okinawa. It was lost to an attack by a Japanese submarine on July 30, 1945.

Reports of the Indianapolis sinking were buried by the news of the Japanese surrender and the end of World War II. Captain Charles McVay III, the commander of the Indianapolis was court-martialed supposedly for abandoning a zigzag sailing course to evade submarine detection in favor of a straight course to reach his destination faster. Ironically, at the court-martial, Lt. Cdr. Mochitsura Hashimoto testified that a zigzag pattern could not protect against submarine attack. Captain Charles McVay III's sailors thought he was made a scapegoat. In the year 2000, thirty two years after he committed suicide, he was absolved of the charge of negligence and an act of the USA Congress cleared his name.

1.14 DISCUSSION

Japan's attack on Pearl Harbor may have been initiated as a response to President Theodore Roosevelt sanctions on Japan, including an oil and raw materials embargo. The USA had an excellent track record cracking the Japanese naval codes and ciphers before World War II. The USA Pacific fleets home base was San Diego. According to Wikipedia:

“James Otto Richardson was an admiral in the United States Navy who served from 1902 to 1947. As Commander in Chief, United States Fleet, he protested against the redeployment of the Pacific portion of the fleet forward to Pearl Harbor, believing that a forward defense was neither practical nor useful, and

that the Pacific Fleet would be the logical first target in the event of war with Japan, vulnerable to air and torpedo attacks.

President Theodore Roosevelt forced its re-location to Hawaii against the protests of Admiral Richardson. Admiral James Otto Richardson protested three times to President Roosevelt and on his third attempt got fired. President Roosevelt kept the aircraft carriers out of port and hung part of the fleet moored in harbor as a lure resulting in 3,000 casualties. The two USA aircraft carriers at Hawaii attempted to ambush the Japanese fleet. The ambush which failed as the second wave of attacks was cancelled by the suspicious Japanese admiral and the Japanese fleet left north of the Hawaiian Islands instead of the expected south. According to Admiral Isoruko Yamamoto: "In the first six to twelve months of a war with the United States and Great Britain I will run wild and win victory upon victory. But then, if the war continues after that, I have no expectation of success".

Japan was fearful of Russia's entry into the war with its territorial claims in the northern Japanese islands, accepted the Potsdam agreement and the Japanese General Nazami signed the documents with American general Westmoreland and other Allies representatives on the Missouri battleship in Tokyo bay, thus ending the ordeal of World War II on August 15, 1945. The Missouri is kept as a floating museum, open to the public, at the Pearl Harbor Naval Base in Hawaii.



Figure 54. Trinity site with evaporated steel tower.



Figure 55. Aerial and ground views of Trinity site after explosion.



Figure 56. Monument at the ground zero of the Trinity site. The site is a historical site open to the public only once a year on the first Saturday of the month of October.

The nuclear age was born in the building of the first reactor, followed by the Manhattan Project, the first nuclear test at the Trinity site and the first use of nuclear devices against Japan ending the Second World War. The forces and knowledge unleashed in these events is sure to affect human life forever. What the future historians will regard as the most important event of this age will be the release of nuclear energy. The genie is out of the bottle. The Nuclear Age is born.

EXERCISES

1. Calculate the speed in meters per second of thermal or kT neutrons with 0.025 eV of energy.
2. If a single fission reaction produces about 200 MeV of energy, use Avogadro's law to calculate the number of grams of U^{235} , U^{233} and of Pu^{239} that would fission to release 1 kT of TNT equivalent of energy. Assume that all the energy release is available, except for the energy carried away by the antineutrinos, and the delayed gamma rays and beta particles in the fission products, which are not fully recoverable.
3. The yield from the Hiroshima device was 12.5 kT of TNT equivalent, and the yield from the Nagasaki device was 22 kT of TNT. Assuming that one critical mass of lead reflected U^{235} Oralloid at about 30 kgs, and one critical mass of Pu^{239} at about 10 kgs were used to generate these yields, compare the energy release efficiencies of the two devices as the fraction or percentage of the fissile material converted into energy in the case of the gun barrel versus the implosion process.

4. Using the exponential growth model to calculate the number of generations needed for the release of 1 kT and 100 kT of TNT equivalent, in what neutron generations are the last 99 percent of the energy released? Use the following data: $\nu = 3.0$, $a = 0.4$, $\ell = 0.1$.
 5. Compare the power in MeV/sec and in Watts of:
 - a) The experimental CP-1 pile,
 - b) The pilot X-10 pile,
 - c) The Hanford plutonium production reactors,
 - d) A modern electrical nuclear power plant.
- Note: The MeV/sec power unit is equivalent to 1.6×10^{-6} ergs/sec or 1.6×10^{-13} Joules/sec or Watts.
6. Calculate the speed in meters per second of neutrons possessing the following energies:
 - a. Fast neutron from fission at 2 MeV,
 - b. Intermediate energy neutron at 10 keV,
 - c. Thermal energy neutrons at 0.025 eV.
 7. Plot the neutron population N as a function of the generation number n using the exponential model for the following values of the neutron multiplication factor k :
 - a) $k=1.0$, critical system,
 - b) $k=0.5$, subcritical system,
 - c) $k=2.0$, supercritical system.

REFERENCES

1. S. Glasstone, Ed., "The Effects of Nuclear Weapons," U. S. Atomic Energy Commission, 1950.
2. S. M. Ulam, "Adventures of a Mathematician," Charles Scribner's Sons, New York, 1976.
3. A. C. Brown, and B. MacDonald, "The Secret History of the Atomic Bomb," Dell Publishing Co., New York, 1977.
4. R. G. Hewlett and O. E. Anderson, Jr., "The New World, A History of the United States Atomic Energy Commission," Volume 1, 1939/1946, U. S. Atomic Energy Commission, 1972.
5. D. S. Saxon et al., "The Effects of Nuclear War," Office of Technology Assessment, Congress of the United States, Washington DC, May 1979.
6. William E. Loewe, "New Radiation Dosimetry Estimates for Hiroshima and Nagasaki," Energy and Technology Review, Lawrence Livermore National Laboratory, pp. 25-36, November 1984.

APPENDIX I

NUCLEAR MILESTONES

- 1789 Martin Klaproth discovers Uranium and names it after the planet Uranus.
- 1895 Wilhelm Röntgen accidentally discovers X-rays when he notices a luminescent screen left near a discharge tube was scintillating. The world immediately appreciates their medical potential. Within five years the British Army is using a mobile x-ray unit to locate bullets and shrapnel in wounded soldiers in the Sudan.
- 1896 Henri Becquerel uses uranium and radium to discover alpha and beta rays, types of radiation. Paul Villard discovers gamma rays.

1896 J. J. Thomson discovers the electron.

1898 Pierre and Marie Curie first use the word “radiation” to describe the rays they were finding. They also postulated the existence of Polonium and discovered Radium. Radium would go on and be used as a treatment for cancer. Also in this year, Samuel Prescott used radiation to kill bacteria in food.

1902 - 1919 Ernest Rutherford and Frederick Soddy establish the theory of nuclear reactions and conduct various experiments to manipulate elements by bombarding them with alpha and beta particles.

1905 Albert Einstein puts forward a theory relating mass and energy, $E = mc^2$.

1911 George von Hevesy conceives the idea of using radioactive tracers. This idea is later applied to medical diagnosis.

1913 Niels Bohr publishes model of the atomic structure as a mini solar system that is still used today. Frederick Proescher publishes the first study on the intravenous injection of radium for therapy of various diseases.

1927 Herman Blumgart, a Boston physician, first uses radioactive tracers to diagnose heart disease.

1932 James Chadwick discovers the neutron, and important component in nuclear fission.

1933 Canada’s first uranium mine, at La Bine Point North West Territory NWT, Canada , later renamed Port Radium, opens for production.

1934 Enrico Fermi showed that neutrons could split many different types of atoms and yield products lighter than their original reactants.

1937 John Livingood, Fred Fairbrother and Glenn Seaborg discover Iron⁵⁹.

1938 John Livingood and Glenn Seaborg discover Iodine¹³¹ and Cobalt⁶⁰ - all isotopes currently used in nuclear medicine.

1938 Otto Hahn and Fritz Strassman, in Germany, replicating Fermi’s experiment proved that when the atoms are split, energy is in turn released; thereby discovering nuclear fission. The discovery of fission proved Einstein’s theory put forward 33 years prior.

1939 Frederic Curie, Halban and Kowarski demonstrate that fission of uranium can cause a chain reaction. They take a first patent on the production of nuclear energy. Scientists around the world petitioned their governments to fund nuclear fission programs. World War II begins.

1940 The Rockefeller Foundation funds the first cyclotron dedicated for biomedical radioisotope production at Washington University in St. Louis, USA.

1942 Fermi and Szilard build Chicago Pile-1, CP-1, the world’s first self-sustaining nuclear fission reaction beneath the stadium in a squash court at the University of Chicago, USA.

1942 - 1945 The Manhattan District Project builds the world’s first Atomic devices. Two devices are dropped on Japan at Hiroshima and Nagasaki. World War II ends.

1944 Atomic Energy of Canada (AECL) opens Canada’s Chalk River Laboratories 180 miles north of Ottawa; by September 1945 the facility went online with the first nuclear reactor outside of the USA. The Zero Energy Experimental Pile (ZEEP) laid the groundwork for eventual development of the CANDU power reactor.

1946 USA Government creates the Atomic Energy Commission, AEC. The commission was created to oversee all nuclear reactors and nuclear research in the USA. Canadian government passes the Atomic Energy Control Act and establishes the Atomic Energy

Control Board, responsible for ensuring that nuclear energy use in Canada meets health, safety, security and environmental standards.

1948 Nuclear chain reaction achieved in ZOE, the first French atomic pile in Fort de Chatillon.

1949 The Soviet Union gets the atomic bomb.

1951 Experimental Breeder Reactor I, EBR-I, starts in Idaho. Breeder reactors create more fissionable material in the chain reaction process than they consume. EBR-I generated the first energy created by nuclear power. The USA Food and Drug Administration (FDA) approve sodium iodide NaI^{131} for use with thyroid patients. It is the first FDA-approved radio-pharmaceutical.

1952 The USA sets off the first thermonuclear device using fusion. In Canada, the AECL is incorporated as a federal crown corporation.

1953 Seeking a way out of the growing nuclear arms race, USA President Dwight D. Eisenhower delivers his "Atoms for Peace" speech to the to the United Nations UN General Assembly, proposing the creation of the "International Atomic Energy Agency", IAEA.

1954 The USSR completes the Obninsk Nuclear Power Plant, the first nuclear power plant to produce electricity 5 MWe for a power grid. President Dwight Eisenhower signs the Atomic Energy Act, opening door to private use of nuclear energy.

1955 The first nuclear powered submarine, the USS Nautilus is launched. Decommissioned in 1980, the Nautilus covered 513,550 nautical miles and was the first submarine to literally cross the geographic North Pole, beneath the arctic sea ice. Arco, Idaho, population 1000, becomes the first USA town to be powered by nuclear energy.

1956 Calder Hall, the world's first commercial nuclear power station, opens in England.

1957 The USA completes its first large-scale nuclear power plant at Shippingport, Pennsylvania. The UN forms the IAEA, the International Atomic Energy Agency to promote nuclear power and stop the spread of nuclear weapons.

1959 In Illinois, the Dresden-1 Nuclear Power Station, the first USA nuclear plant built without government funding, achieves self-sustaining nuclear reaction. First fast breeder reactor begins operation in the Obninsk Scientific Center, Russia at 12 MWe.

1960 The Atomic Energy Commission announces the successful development of a 220-pound nuclear reactor designed to provide electric power for space vehicles. World-wide, 15 nuclear power reactors were in operation with a combined electricity generation capacity of 1,087 MWe.

1962 David Kuhl introduces emission reconstruction tomography. This method later became known as SPECT and PET. It was extended in radiology to transmission X-ray scanning, known as CT. Canada's first nuclear power plant, the Nuclear Power Demonstration (NPD), begins operation in Rolphton, Ontario.

1963 The USA and Soviet Union sign the Limited Test Ban Treaty, which prohibits underwater, atmospheric, and outer space nuclear tests. More than 100 countries have ratified the treaty since 1963.

1964 The world's first nuclear powered lighthouse, the "Baltimore Light," on the Chesapeake Bay in Maryland, starts operation. A 60-Watt radioisotope nuclear generator, 345 inches high, weighing 4,600 pounds, supplies a continuous flow of electricity for 10 years without refueling. In Canada, the Ontario provincial government announces plans to build large-scale CANDU nuclear reactors at Pickering. Pickering Unit 1 starts operation in 1971.

1965 The USA launches the first nuclear reactor in space.

1968 - 1986 The Nuclear Non-proliferation Treaty (NPT) calling for halting the spread of nuclear weapons capabilities is signed. By 1970, more than 50 countries had ratified the NPT. By 1986, more than 130 countries had ratified it.

1970 World-wide, 84 nuclear power reactors were in operation with a combined electricity generation capacity of 17,656 MWe.

1971 The American Medical Association officially recognizes nuclear medicine as a medical specialty.

1972 Computer axial tomography, commonly known as CAT scanning, is introduced. A CAT scan combines many high-definition, cross-sectional x-rays to produce a two-dimensional image of a patient's anatomy.

1973 Phenix, first French fast breeder power plant in operation in Marcoule goes online at 250 MWe.

1974 India detonates its first nuclear device, leading to the development of the Nuclear Suppliers Group to set guidelines that restrict the export of certain nuclear and dual-use materials, equipment and technologies.

1977 USA President Jimmy Carter bans the recycling of used nuclear fuel from commercial reactors. The Voyager 2 spacecraft is launched with its electrical systems powered by the decay of Plutonium²³⁸ pellets. Canada's department of Energy, Mines and Resources commissions an independent expert panel to study and report on safe, long-term storage of radioactive waste. The panel recommends the development of a national plan.

1978 David Goldenberg uses radiolabeled antibodies to image tumors in humans. The Canadian Nuclear Fuel Waste Management Program is established to develop safe and permanent disposal methods for used nuclear fuel. AECL is given the task of researching and developing the concept of a deep geologic disposal site in the Canadian Shield.

1979 The Three Mile Island TMI nuclear power plant near Harrisburg, Pennsylvania suffers a partial core meltdown. The event sparked many improvements in nuclear power plant operations, from emergency response planning to reactor operator training.

1980 The Joint FAO/IAEA/WHO Expert Committee on the Wholesomeness of Irradiated Food (JECFI), evaluated in 1964, 1969, 1976, and 1980 the results of wholesomeness and safety testing. In 1980, JECFI approves all irradiated foods treated with a maximum average dose of 10 kGy. World-wide, 245 nuclear power reactors were in operation with a combined electricity generation capacity of 133,037 MWe.

1982 Steve Larson and Jeff Carrasquillo use Iodine¹³¹ labeled monoclonal antibodies to treat cancer patients with malignant melanoma. Natural Resources Canada establishes the Low-Level Radioactive Waste Management Office to oversee the handling and storage of low-level radioactive wastes from past industrial operations and research activities in Canada.

1983 Nuclear power generates more energy than natural gas in the USA.

1986 The Chernobyl accident in the Ukraine occurs. Subsequently, numerous initiatives were taken to strengthen global nuclear governance, including:

The 1986 Convention on Early Notification of a Nuclear Accident,

The 1986 Convention on Assistance in the Case of a Nuclear Accident or Radiological Emergency

The 1994 Convention on Nuclear Safety (CNS), the first legally binding multilateral nuclear safety treaty

The 1997 Joint Convention on the Safety of Spent Fuel Management and on the Safety of Radioactive Waste Management

The USA Federal Drug Administration, FDA approves irradiation of fruits and vegetables and other foods up to doses of one kGy.

1987 Nuclear Waste Policy Amendments Act designates Yucca Mountain, Nevada as a candidate for the USA's first geological repository for high-level radioactive waste and spent nuclear fuel.

1990 World-wide, 416 nuclear power reactors were in operation with a combined electricity generation capacity of 318,253 MWe.

1994 Canada's AECL submits its report on deep geologic disposal of nuclear waste. The government's Environmental Assessment Agency Panel begins reviews and public consultations in Ontario, Québec, New Brunswick, Manitoba and Saskatchewan, the five provinces in which nuclear waste is either produced or where nuclear R&D facilities are located

1995 Megatons to Megawatts program launched by the USA and Russia. The most successful non-proliferation program to date, over 18,000 nuclear warheads have been recycled into Low Enriched Uranium (LEU) used to produce fuel for American nuclear power plants. The program ends at the close of 2013.

1997 Canadian government passes the Nuclear Safety and Control Act, replacing the Atomic Control Act of 1946 and designed to improve the regulatory framework for the nuclear industry. It also replaces the Atomic Energy Control Board with a new regulator, the Canadian Nuclear Safety Commission (CNSC). The IAEA's Joint Convention on the Safety of Spent Fuel Management and the Safety of Radioactive Waste is signed by 15 states. It is the first international agreement to promote the safety of spent fuel and the management of radioactive waste. It went into effect in June 2001 and, as of 2012, has 67 participating countries.

1998 Canada's Environmental Assessment Agency Panel completes its review of the deep geologic concept. It finds the safety of the AECL proposal technically sound but concludes that it remains a socially unacceptable plan in Canada.

1997 With the positive implications for the nuclear power industry, the UN's Kyoto Protocol is agreed to. The protocol is designed to set binding obligations on participating nations to reduce greenhouse gases. It goes into effect in 2005.

2000 World-wide, 435 nuclear power reactors were in operation with a combined electricity generation capacity of 349,999 MWe. USA Department of Energy (DOE) convenes representatives from 9 countries to collaborate in the development of Generation IV nuclear energy systems. By 2012, 13 countries are active participants in the Generation IV International Forum (GIF).

2001 The term 'Nuclear Renaissance' is coined to describe a possible nuclear power industry revival driven by fossil fuel prices and international pressure to reduce greenhouse gases.

2002 The Canadian government passes the Nuclear Fuel Waste Act. The new legislation calls on nuclear power producers to create the Nuclear Waste Management Organization.

2008 The IAEA publishes "Climate Change and Nuclear Power" to promote nuclear power solutions to the world's greenhouse gas emission targets.

2010 World-wide, 441 nuclear power reactors were in operation with a combined electricity generation capacity of 375,280 MWe.

2011 The Fukushima Daiichi plant in Japan undergoes a flooding Station Blackout accident after unprecedented earthquake and tsunami sweep the country. Some of the outcomes include increased regulatory oversight measures and further strengthening of safety features at nuclear plants around the world.

2012 World-wide, 437 nuclear power reactors were in operation with a combined electricity generation capacity of 371,762 MWe.

APPENDIX II

ON THE USE OF NUCLEAR WEAPONS ON JAPAN

A monument was built at ground zero in Hiroshima. It features the words: “Let all the souls here rest in peace; for we shall not repeat the evil.”

On May 27, 2016 at Hiroshima, USA President Barack Obama paid his respects to the Japanese people, and said the following words: “The very spark that marks us as a species – our thoughts, our imagination, our language, our tool-making, our ability to set ourselves apart from nature and bend it to our will – those very things also give us the capacity for unmatched destruction... Technological progress without an equivalent progress in human institutions can doom us. The scientific revolution that led to the splitting of the atom requires a moral revolution as well.”

The following is a full transcript of President Barack Obama’s speech in Hiroshima, Japan, as recorded by The New York Times:

“Seventy-one years ago, on a bright cloudless morning, death fell from the sky and the world was changed. A flash of light and a wall of fire destroyed a city and demonstrated that mankind possessed the means to destroy itself.

Why do we come to this place, to Hiroshima? We come to ponder a terrible force unleashed in a not-so-distant past. We come to mourn the dead, including over 100,000 Japanese men, women and children, thousands of Koreans, a dozen Americans held prisoner.

Their souls speak to us. They ask us to look inward, to take stock of who we are and what we might become.

It is not the fact of war that sets Hiroshima apart. Artifacts tell us that violent conflict appeared with the very first man. Our early ancestors having learned to make blades from flint and spears from wood used these tools not just for hunting but against their own kind. On every continent, the history of civilization is filled with war, whether driven by scarcity of grain or hunger for gold, compelled by nationalist fervor or religious zeal. Empires have risen and fallen. Peoples have been subjugated and liberated. And at each juncture, innocents have suffered, a countless toll, their names forgotten by time.

The world war that reached its brutal end in Hiroshima and Nagasaki was fought among the wealthiest and most powerful of nations. Their civilizations had given the world great cities and magnificent art. Their thinkers had advanced ideas of justice and harmony and truth. And yet the war grew out of the same base instinct for domination or conquest that had caused conflicts among the simplest tribes, an old pattern amplified by new capabilities and without new constraints.

In the span of a few years, some 60 million people would die. Men, women, children, no different than us. Shot, beaten, marched, bombed, jailed, starved, gassed to death. There are many sites around the world that chronicle this war, memorials that tell stories of courage and heroism, graves and empty camps that echo of unspeakable depravity.

Yet in the image of a mushroom cloud that rose into these skies, we are most starkly reminded of humanity's core contradiction. How the very spark that marks us as a species, our thoughts, our imagination, our language, our toolmaking, our ability to set ourselves apart from nature and bend it to our will — those very things also give us the capacity for unmatched destruction.

How often does material advancement or social innovation blind us to this truth? How easily we learn to justify violence in the name of some higher cause.

Every great religion promises a pathway to love and peace and righteousness, and yet no religion has been spared from believers who have claimed their faith as a license to kill.

Nations arise telling a story that binds people together in sacrifice and cooperation, allowing for remarkable feats. But those same stories have so often been used to oppress and dehumanize those who are different.

Science allows us to communicate across the seas and fly above the clouds, to cure disease and understand the cosmos, but those same discoveries can be turned into ever more efficient killing machines.

The wars of the modern age teach us this truth. Hiroshima teaches this truth. Technological progress without an equivalent progress in human institutions can doom us. The scientific revolution that led to the splitting of an atom requires a moral revolution as well.

That is why we come to this place. We stand here in the middle of this city and force ourselves to imagine the moment the bomb fell. We force ourselves to feel the dread of children confused by what they see. We listen to a silent cry. We remember all the innocents killed across the arc of that terrible war and the wars that came before and the wars that would follow.

Mere words cannot give voice to such suffering. But we have a shared responsibility to look directly into the eye of history and ask what we must do differently to curb such suffering again.

Some day, the voices of the hibakusha will no longer be with us to bear witness. But the memory of the morning of Aug. 6, 1945, must never fade. That memory allows us to fight complacency. It fuels our moral imagination. It allows us to change.

And since that fateful day, we have made choices that give us hope. The United States and Japan have forged not only an alliance but a friendship that has won far more for our people than we could ever claim through war. The nations of Europe built a union that replaced battlefields with bonds of commerce and democracy. Oppressed people and nations won liberation. An international community established institutions and treaties that work to avoid war and aspire to restrict and roll back and ultimately eliminate the existence of nuclear weapons.

Still, every act of aggression between nations, every act of terror and corruption and cruelty and oppression that we see around the world shows our work

is never done. We may not be able to eliminate man's capacity to do evil, so nations and the alliances that we form must possess the means to defend ourselves. But among those nations like my own that hold nuclear stockpiles, we must have the courage to escape the logic of fear and pursue a world without them.

We may not realize this goal in my lifetime, but persistent effort can roll back the possibility of catastrophe. We can chart a course that leads to the destruction of these stockpiles. We can stop the spread to new nations and secure deadly materials from fanatics.

And yet that is not enough. For we see around the world today how even the crudest rifles and barrel bombs can serve up violence on a terrible scale. We must change our mind-set about war itself. To prevent conflict through diplomacy and strive to end conflicts after they have begun. To see our growing interdependence as a cause for peaceful cooperation and not violent competition. To define our nations not by our capacity to destroy but by what we build. And perhaps, above all, we must reimagine our connection to one another as members of one human race.

For this, too, is what makes our species unique. We are not bound by genetic code to repeat the mistakes of the past. We can learn. We can choose. We can tell our children a different story, one that describes a common humanity, one that makes war less likely and cruelty less easily accepted.

We see these stories in the hibakusha. The woman who forgave a pilot who flew the plane that dropped the atomic bomb because she recognized that what she really hated was war itself. The man who sought out families of Americans killed here because he believed their loss was equal to his own.

My own nation's story began with simple words: All men are created equal and endowed by our creator with certain unalienable rights including life, liberty and the pursuit of happiness. Realizing that ideal has never been easy, even within our own borders, even among our own citizens. But staying true to that story is worth the effort. It is an ideal to be strived for, an ideal that extends across continents and across oceans. The irreducible worth of every person, the insistence that every life is precious, the radical and necessary notion that we are part of a single human family — that is the story that we all must tell.

That is why we come to Hiroshima. So that we might think of people we love. The first smile from our children in the morning. The gentle touch from a spouse over the kitchen table. The comforting embrace of a parent. We can think of those things and know that those same precious moments took place here, 71 years ago.

Those who died, they are like us. Ordinary people understand this, I think. They do not want more war. They would rather that the wonders of science be focused on improving life and not eliminating it. When the choices made by nations, when the choices made by leaders, reflect this simple wisdom, then the lesson of Hiroshima is done.

The world was forever changed here, but today the children of this city will go through their day in peace. What a precious thing that is. It is worth protecting, and then extending to every child. That is a future we can choose, a future in which

Hiroshima and Nagasaki are known not as the dawn of atomic warfare but as the start of our own moral awakening.”

Japanese Admiral Isoroku Yamamoto is quoted as: “I fear all we have done is to awaken a sleeping giant and fill him with a terrible resolve.” The prevalent thinking is that the use of nuclear bombs on Hiroshima and Nagasaki was meant to end World War II and save both American and Japanese lives. However, dissenting views existed at the time.

The USA Strategic Bombing Survey group, assigned by President Harry Truman to study the air attacks on Japan, produced a report in July of 1946 that concluded:

“Based on a detailed investigation of all the facts and supported by the testimony of the surviving Japanese leaders involved, it is the Survey’s opinion that certainly prior to 31 December 1945 and in all probability prior to 1 November 1945, Japan would have surrendered even if the atomic bombs had not been dropped, even if Russia had not entered the war, and even if no invasion had been planned or contemplated.”

General and later President Dwight Eisenhower, then Supreme Commander of all Allied Forces, and the officer who created most of America’s WWII military plans for Europe and Japan, said: “The Japanese were ready to surrender and it wasn’t necessary to hit them with that awful thing,” Newsweek, 11/11/1963, “Ike on Ike.” President Dwight Eisenhower also noted:

“In July 1945, Secretary of War Stimson, visiting my headquarters in Germany, informed me that our government was preparing to drop an atomic bomb on Japan. I was one of those who felt that there were a number of cogent reasons to question the wisdom of such an act. The Secretary, upon giving me the news of the successful bomb test in New Mexico, and of the plan for using it, asked for my reaction, apparently expecting a vigorous assent. During his recitation of the relevant facts, I had been conscious of a feeling of depression and so I voiced to him my grave misgivings, first on the basis of my belief that Japan was already defeated and that dropping the bomb was completely unnecessary, and secondly because I thought that our country should avoid shocking world opinion by the use of a weapon whose employment was, I thought, no longer mandatory as a measure to save American lives. It was my belief that Japan was, at that very moment, seeking some way to surrender with a minimum loss of ‘face’. The Secretary was deeply perturbed by my attitude.”

Secretary of War Stimson presented a utilitarian argument that the bombing prevented a greater degree of overall suffering, according to Japanese philosopher Masahiro Morioka. In a paper, he drew parallels between the Hiroshima and Nagasaki bombings and the utilitarian dilemma raised by the “trolley problem”. Originally proposed by philosopher Phillipa Foot, one of the versions of this thought experiment or Gedanken experiment asks people to weigh up whether they would sacrifice one person’s life to save five, by redirecting the track of a runaway trolley to kill that individual. In university lectures in Japan, Masahiro Morioka presented this version of the trolley problem to his students, they responded that they would divert the trolley so that only one person dies. He says: “They were shocked to realize that they made the same decision

as Truman and Stimson”. The sanitized logic of a utilitarian greater good argument obscures the perspective of the dead and injured: “How the victims would think is erased from the problem.” Masahiro Morioka advances that the action is lacking in humanity: “By making a justification, we are led to pretend that the perspective of the victims did not exist at all, which is morally and spiritually wrong, problematic and repugnant.”

A hint of contrition came from the diary of the secretary of commerce, who wrote that President Harry Truman called a halt to any further bombing after Nagasaki because: “He did not like the idea of killing ‘all those kids’.”

Admiral William Leahy, the highest ranking member of the USA military from 1942 until retiring in 1949, who was the first de facto Chairman of the Joint Chiefs of Staff, and who was at the center of all major American military decisions in World War II, wrote:

“It is my opinion that the use of this barbarous weapon at Hiroshima and Nagasaki was of no material assistance in our war against Japan. The Japanese were already defeated and ready to surrender because of the effective sea blockade and the successful bombing with conventional weapons. The lethal possibilities of atomic warfare in the future are frightening. My own feeling was that in being the first to use it, we had adopted an ethical standard common to the barbarians of the Dark Ages. I was not taught to make war in that fashion, and wars cannot be won by destroying women and children.”

General Douglas MacArthur concurred:

“MacArthur’s views about the decision to drop the atomic bomb on Hiroshima and Nagasaki were starkly different from what the general public supposed When I asked General MacArthur about the decision to drop the bomb, I was surprised to learn he had not even been consulted. What, I asked, would his advice have been? He replied that he saw no military justification for the dropping of the bomb. The war might have ended weeks earlier, he said, if the United States had agreed, as it later did anyway, to the retention of the institution of the Emperor. The Potsdam declaration in July, demanded that Japan surrender unconditionally or face ‘prompt and utter destruction.’ MacArthur was appalled. He knew that the Japanese would never renounce their Emperor, and that without him an orderly transition to peace would be impossible anyhow, because his people would never submit to Allied occupation unless he ordered it. Ironically, when the surrender did come, it was conditional, and the condition was a continuation of the imperial reign. Had the General’s advice been followed, the resort to atomic weapons at Hiroshima and Nagasaki might have been unnecessary.”

Assistant Secretary of War John McLoy noted:

“I have always felt that if, in our ultimatum to the Japanese government issued from Potsdam [in July 1945], we had referred to the retention of the Emperor as a constitutional monarch and had made some reference to the reasonable accessibility of raw materials to the future Japanese government, it would have been accepted. Indeed, I believe that even in the form it was delivered, there was some

disposition on the part of the Japanese to give it favorable consideration. When the war was over I arrived at this conclusion after talking with a number of Japanese officials who had been closely associated with the decision of the then Japanese government, to reject the ultimatum, as it was presented. I believe we missed the opportunity of effecting a Japanese surrender, completely satisfactory to us, without the necessity of dropping the bombs.”

Under Secretary of the Navy Ralph Bird said:

“I think that the Japanese were ready for peace, and they already had approached the Russians and, I think, the Swiss. And that suggestion of [giving] a warning [of the atomic bomb] was a face-saving proposition for them, and one that they could have readily accepted. In my opinion, the Japanese war was really won before we ever used the atom bomb. Thus, it wouldn’t have been necessary for us to disclose our nuclear position and stimulate the Russians to develop the same thing much more rapidly than they would have if we had not dropped the bomb.” War Was Really Won Before We Used A-Bomb, U.S. News and World Report, 8/15/60, pg. 73-75.

He also noted:

“It definitely seemed to me that the Japanese were becoming weaker and weaker. They were surrounded by the Navy. They couldn’t get any imports and they couldn’t export anything. Naturally, as time went on and the war developed in our favor it was quite logical to hope and expect that with the proper kind of a warning the Japanese would then be in a position to make peace, which would have made it unnecessary for us to drop the bomb and have had to bring Russia in.”

General Curtis LeMay, the Army Air Force “hawk,” stated publicly shortly after the nuclear bombs were dropped on Japan: “The war would have been over in two weeks. . . . The atomic bomb had nothing to do with the end of the war at all.”

The Vice Chairman of the U.S. Bombing Survey Paul Nitze wrote:

“[I] concluded that even without the atomic bomb, Japan was likely to surrender in a matter of months. My own view was that Japan would capitulate by November 1945. Even without the attacks on Hiroshima and Nagasaki, it seemed highly unlikely, given what we found to have been the mood of the Japanese government, that a U.S. invasion of the islands [scheduled for November 1, 1945] would have been necessary.”

Deputy Director of the Office of Naval Intelligence Ellis Zacharias wrote: “Just when the Japanese were ready to capitulate, we went ahead and introduced to the world the most devastating weapon it had ever seen and, in effect, gave the go-ahead to Russia to swarm over Eastern Asia. Washington decided that Japan had been given its chance and now it was time to use the A-bomb.

I submit that it was the wrong decision. It was wrong on strategic grounds. And it was wrong on humanitarian grounds. Ellis Zacharias, *How We Bungled the Japanese Surrender*, Look, 6/6/1950.

Brigadier General Carter Clarke – the military intelligence officer in charge of preparing summaries of intercepted Japanese cables for President Truman and his advisors said: “When we didn’t need to do it, and we knew we didn’t need to do it, and they knew that we knew we didn’t need to do it, we used them as an experiment for two atomic bombs.”

Other high-level military officers concurred. For instance, the commander in chief of the U.S. Fleet and Chief of Naval Operations, Ernest J. King, stated that the naval blockade and prior bombing of Japan in March of 1945, had rendered the Japanese helpless and that the use of the atomic bomb was both unnecessary and immoral. Fleet Admiral Chester W. Nimitz was reported to have said in a press conference on September 22, 1945, that: “The Admiral took the opportunity of adding his voice to those insisting that Japan had been defeated before the atomic bombing and Russia’s entry into the war.” In a subsequent speech at the Washington Monument on October 5, 1945, Admiral Nimitz stated: “The Japanese had, in fact, already sued for peace before the atomic age was announced to the world with the destruction of Hiroshima and before the Russian entry into the war.” About July 20, 1945, General Eisenhower had urged Truman, in a personal visit, not to use the atomic bomb. Eisenhower’s assessment was “It wasn’t necessary to hit them with that awful thing, to use the atomic bomb, to kill and terrorize civilians, without even attempting [negotiations], was a double crime.” Eisenhower also stated that it wasn’t necessary for Truman to “succumb” to [the tiny handful of people putting pressure on the president to drop atom bombs on Japan.]

British officers were of the same mind. General Sir Hastings Ismay, Chief of Staff to the British Minister of Defence, said to Prime Minister Churchill that “when Russia came into the war against Japan, the Japanese would probably wish to get out on almost any terms short of the dethronement of the Emperor.” On hearing that the atomic test was successful, Ismay’s private reaction was one of “revulsion.”

Special Assistant to the Secretary of the Navy Lewis Strauss proposed to Secretary of the Navy James Forrestal that a non-lethal demonstration of atomic weapons would be enough to convince the Japanese to surrender, and the Navy Secretary agreed:

“I proposed to Secretary Forrestal that the weapon should be demonstrated before it was used. Primarily it was because it was clear to a number of people, myself among them, that the war was very nearly over. The Japanese were nearly ready to capitulate... My proposal to the Secretary was that the weapon should be demonstrated over some area accessible to Japanese observers and where its effects would be dramatic. I remember suggesting that a satisfactory place for such a demonstration would be a large forest of cryptomeria trees not far from Tokyo. The cryptomeria tree is the Japanese version of our redwood... I anticipated that a bomb detonated at a suitable height above such a forest... would lay the trees out in windrows from the center of the explosion in all directions as though they were matchsticks, and, of course, set them afire in the center. It seemed to me that a demonstration of this sort would prove to the Japanese that we could destroy any of their cities at will... Secretary Forrestal agreed wholeheartedly with the recommendation. It seemed to me that such a weapon was not necessary to bring the war to a successful conclusion, that once used it would find its way into the armaments of the world.”

General George Marshall agreed. Contemporary documents show that Marshall felt “these weapons might first be used against straight military objectives such as a large naval installation and then if no complete result was derived from the effect of that, he thought we ought to designate a number of large manufacturing areas from which the people would be warned to leave—telling the Japanese that we intend to destroy such centers....”

Historian Doug Long notes:

“U.S. Nuclear Regulatory Commission historian J. Samuel Walker has studied the history of research on the decision to use nuclear weapons on Japan. In his conclusion he writes, “The consensus among scholars is that the bomb was not needed to avoid an invasion of Japan and to end the war within a relatively short time. It is clear that alternatives to the bomb existed and that Truman and his advisors knew it.” (J. Samuel Walker, *The Decision to Use the Bomb: A Historiographical Update*, *Diplomatic History*, Winter 1990).

Politician Herbert Hoover said: “The Japanese were prepared to negotiate all the way from February 1945...up to and before the time the atomic bombs were dropped; ...if such leads had been followed up, there would have been no occasion to drop the [atomic] bombs.”

Under Secretary of State Joseph Grew noted: “In the light of available evidence I myself and others felt that if such a categorical statement about the [retention of the] dynasty had been issued in May, 1945, the surrender-minded elements in the [Japanese] Government might well have been afforded by such a statement a valid reason and the necessary strength to come to an early clear cut decision.”

On September 9, 1945, Admiral William F. Halsey, commander of the Third Fleet, was publicly quoted extensively as stating that the atomic bomb was used because “the scientists had a toy and they wanted to try it out.” He further stated: “The first atomic bomb was an unnecessary experiment. It was a mistake to ever drop it.”

Albert Einstein – an important catalyst for the development of the atom bomb, but not directly connected with the Manhattan Project, said: “A great majority of scientists were opposed to the sudden employment of the atom bomb.” In Einstein’s judgment, the dropping of the bomb was a political, diplomatic decision rather than a military or scientific decision.

Some of the Manhattan Project scientists wrote directly to the secretary of defense in 1945 to try to dissuade him from dropping the bomb: “We believe that these considerations make the use of nuclear bombs for an early, unannounced attack against Japan inadvisable. If the United States would be the first to release this new means of indiscriminate destruction upon mankind, she would sacrifice public support throughout the world, precipitate the race of armaments, and prejudice the possibility of reaching an international agreement on the future control of such weapons.” (Political and Social Problems, Manhattan Engineer District Records, Harrison-Bundy files, folder # 76, National Archives, also in: Martin Sherwin, *A World Destroyed*, 1987 edition).

The scientists questioned the ability of destroying Japanese cities with atomic bombs to bring surrender when destroying Japanese cities with conventional bombs had not done so, and – like some of the military officers quoted above – recommended a demonstration of the atomic bomb for Japan in an unpopulated area.

In the years since the two atomic bombs were dropped on Japan, a number of historians have suggested that the weapons had a two-pronged objective. It has been suggested that the second objective was to demonstrate the new weapon of mass destruction to the Soviet Union. By August 1945, relations between the Soviet Union and the United States had deteriorated badly. The Potsdam Conference between U.S. President Harry S. Truman, Russian leader Joseph Stalin, and Winston Churchill (before being replaced by Clement Attlee) ended just four days before the bombing of Hiroshima. The meeting was marked by recriminations and suspicion between the Americans and Soviets. Russian armies were occupying most of Eastern Europe. Truman and many of his advisers hoped that the U.S. atomic monopoly might offer diplomatic leverage with the Soviets. In this fashion, the dropping of the atomic bomb on Japan can be seen as the first shot of the Cold War.

New Scientist reported in 2005: “The US decision to drop atomic bombs on Hiroshima and Nagasaki in 1945 was meant to kick-start the Cold War rather than end the Second World War, according to two nuclear historians who say they have new evidence backing the controversial theory.” Causing a fission reaction in several kilograms of uranium and plutonium and killing over 200,000 people 60 years ago was done more to impress the Soviet Union than to cow Japan, they say. And the USA President who took the decision, Harry Truman, was culpable, they add: “He knew he was beginning the process of annihilation of the species,” says Peter Kuznick, director of the Nuclear Studies Institute at American University in Washington DC, USA. “It was not just a war crime; it was a crime against humanity.”

Studies of the USA, Japanese and Soviet diplomatic archives suggest that Truman’s main motive was to limit Soviet expansion in Asia, Kuznick claims. Japan surrendered because the Soviet Union began an invasion a few days after the Hiroshima bombing, not because of the atomic bombs themselves, he says. According to an account by Walter Brown, assistant to then-USA secretary of state James Byrnes, Truman agreed at a meeting three days before the bomb was dropped on Hiroshima that Japan was “looking for peace”. Truman was told by his army generals, Douglas MacArthur and Dwight Eisenhower, and his naval chief of staff, William Leahy, that there was no military need to use the bomb.

Instead of allowing other options to end the war, such as letting the Soviets attack Japan with ground forces], the United States rushed to use two atomic bombs at almost exactly the time that an August 8 Soviet attack had originally been scheduled: Hiroshima on August 6 and Nagasaki on August 9. The timing itself has obviously raised questions among many historians. The available evidence, though not conclusive, strongly suggests that the atomic bombs may well have been used in part because American leaders “preferred”—as Pulitzer Prize-winning historian Martin Sherwin has put it—to end the war with the bombs rather than the Soviet attack. Impressing the Soviets during the early diplomatic sparring that ultimately became the Cold War also appears likely to have been a significant factor.

Before his death, General George C. Marshall quietly defended the decision, but for the most part he is on record as repeatedly saying that it was not a military decision, but rather a political one.

Oxford University philosopher Toby Ord in his book *The Precipice* argues that the explosive power of thermonuclear bombs is so great in the 21st Century that they pose an existential risk of triggering a nuclear winter, caused by smoke from firestorms blocking sunlight for years: “Hundreds of millions of direct deaths from the explosions would be followed by billions of deaths from starvation, and – potentially – by the end of humanity itself.” Toby Ord argues that human extinction would be a disaster of such magnitude that working to prevent it should be the

world's number one moral concern. Not only because everybody on Earth would perish, but also because it would mean that trillions and trillions of as-yet unborn people would not live – and flourish – in the coming millennia.

APPENDIX III

THE INFORMATION WAR IN THE PACIFIC, 1945

by Josette H. Williams.

There is no question that the Allies' superior military power and determined spirit defeated Japan. But it was the Allies' communication network that provided war information directly to the Japanese people and an unprecedented response by the Emperor that pushed Japan to accept this defeat. What follows is the story of the US Office of War Information (OWI) and the dramatic role it played in the surrender of the Japanese empire.

The Office of War Information

The contributions of the Office of War Information at the end of the war in the Pacific have been cited briefly in many publications, but the full story has never been told¹ OWI was responsible for using information warfare to promote distrust of Japanese military leaders, lower Japanese military and civilian morale, and encourage surrender. Information was disseminated by radio and leaflet both to the Japanese mainland and to enemy forces hidden on Allied-occupied Pacific islands.

OWI was manned by civilians and supported by military liaison personnel. The Director, Elmer Davis, reported to Secretary of State James Byrnes. Policy decisions were subject to the approval of the Joint Chiefs of Staff, coordinated by Secretary of War Henry Stimson. Edward Barrett managed the Overseas Branch; Bradford Smith was chief of Central Pacific Operations in Honolulu; and Richard Hubert, the author's father, headed the forward area on Saipan.

From Saipan [captured by the U.S. in July 1944], OWI bombarded Japan with radio messages through its 50,000-watt standard-wave station on Saipan, Radio KSAI. The station also picked up 100,000-watt shortwave transmissions from the OWI station in Honolulu and relayed them to Japan. Japanese language broadcasts consisted of news on the status of the war, bombing warnings, and messages from Japanese prisoners of war on Saipan urging surrender. KSAI radio transmissions served many purposes: to Japan's civilian government, they were a vital source of news, received at a time when the fanaticism of the Japanese militarists denied civilian leaders access to information about the status of the war; to hidden Japanese soldiers on occupied Pacific islands, they tempted surrender by promising fair treatment as prisoners of war; and to Allied flight crews, the around-the-clock OWI radio transmissions beamed home the B-29s, saving planes and lives.²

At the same time, newspapers and leaflets in the Japanese language were printed on Saipan. From there, Air Force B-29s flying at 20,000 feet dropped 500-pound M-16 fire bomb containers converted into leaflet casings. These opened at 4,000 feet to deploy millions of leaflets, effectively covering a whole Japanese city with information. In just the last three months of formal psychological warfare, OWI produced and deployed over 63 million leaflets informing the Japanese people of the true status of the war and providing advance warning to 35 cities targeted for destruction.

Postwar surveys showed that the Japanese people trusted the accuracy of the leaflets and many residents of the targeted cities prepared immediately to leave their homes. The Japanese government regarded the leaflets with such concern that it ordered the arrest of those who kept or even read the leaflets and did not turn them in to their local police stations. Outside Japan, leaflets promoting the surrender of individual Japanese soldiers and civilians were dropped near cave and tunnel hideouts on islands that had been captured by the Allies.⁵

Japan's Internal Frictions

Japan had two governments in 1945: one was a military government determined to fight to the last; the other was a civilian government that had long recognized the need to surrender. The military clearly held the upper hand, rendering the civilian leaders impotent through political intimidation and threats of imprisonment.

Civil-military friction, disagreements within political factions, and intergenerational tensions resulted in a bewildering array of conflicting reports on current conditions being disseminated to the Japanese people. The job of the US Office of War information was to cut through the confusion in Japan and its occupied territories, and to convince the Emperor, the politicians, and the civilians that victory was already in the hands of the Allies.

There is little doubt that Japanese government agencies, military and civilian alike, realized by mid-summer 1945 that their country could not win the war. Japan's cities were being destroyed almost at will. Although attempting to avoid the Emperor's palace, the Allies had devastated the capital in only six hours of bombing on 9-10 March 1945, leaving 100,000 dead and over 1,000,000 homeless, an even worse toll than from the later atomic bombing of Hiroshima. The Japanese military maintained a defiant stance, even as they recognized the need to shift from aggression to defense of their homeland.⁶ They were well prepared, both psychologically and technically, for this final stand. The Allies never underestimated (as we, perhaps, sometimes do today) the desire of Japan's military leaders to preserve their honor by fighting literally to the last man, woman, and child.

Broadcasting the Surrender Offer

On 26 July 1945, the heads of state of the United States, Great Britain, and the Soviet Union, meeting in Potsdam, Germany, agreed to give Japan an opportunity to end the war. Their terms called for the disarmament and abolition of the Japanese military; elimination of military influence in political forums; Allied occupation of Japan; liberation of Pacific territories gained by Japan since 1914; swift justice for war criminals; maintenance of non-military industries; establishment of freedom of speech, religion and thought; and introduction of respect for fundamental human rights. The final section demanded that the government of Japan "proclaim now the unconditional surrender of all Japanese armed forces." The alternative for Japan was "prompt and utter destruction."⁸

By 7:00 p.m. on the very day of the Potsdam Proclamation, OWI's station KSAI began broadcasting the surrender terms to the Japanese nation at regular intervals. OWI also printed the full text of the offer in the Japanese language and dropped over 3 million leaflets by B-29 aircraft. Thus Japanese officials learned of the Potsdam conditions a day ahead of the official communication sent through diplomatic channels.

Japan's Cabinet and the Supreme Council for the Direction of the War were immediately called into joint session. They met almost continually from 26 July through 14 August. Arguments over whether, when, and under what conditions Japan should surrender continued right through the bombing of Hiroshima and Nagasaki. On 27 July, after a routine meeting not attended by Japan's civilian Foreign Minister, the militarists released notification to the world's media that Japan rejected the Potsdam offer.⁹

Stepped-Up Bombing

By noon on 28 July, OWI's presses on Saipan were rolling with notices warning civilians to evacuate 35 Japanese cities scheduled to be bombed within the next few days. About 1 million leaflets fell on the targeted cities whose names appeared in Japanese writing under a picture of five airborne B-29s releasing bombs. Given the extent of the effort, it is extraordinary that many Americans are not aware that Japanese cities were warned prior to being bombed. Even today, members of the B-29 crews recall their fears that the warnings would make them easier targets for Japanese planes and antiaircraft artillery. However, they concurred with Gen. Curtis LeMay's proposal at the time. Military newspapers featured the unprecedented action under such headlines as "B-29 Command Now Calling Its Shots" and 580 B-29s Follow Up Leaflet Warnings With 3800 Tons Of Fire And Explosives...

Advertising the Destruction of Hiroshima

At 2:45 a.m. on 6 August, the Allies' B-29 "Enola Gay" left the island of Tinian near Saipan. Its primary target was Hiroshima, where the 2nd Japanese Army stood poised to defend against an expected Allied invasion of their homeland. At 8:15 a.m., the "Enola Gay" destroyed Hiroshima with a single atomic bomb.

Back on Saipan, the OWI presses were turning out leaflets that revealed the special nature of Hiroshima's destruction and predicted similar fates for more Japanese cities in the absence of immediate acceptance of the terms of the Potsdam agreement. By 9 August, more than 5 million leaflets about the atom bomb had been released over major Japanese cities. The OWI radio station beamed a similar message to Japan every 15 minutes.

Indecision in Tokyo

The Supreme Council for the Direction of the War, composed of four military and two civilian members, was deadlocked, unable to present the Cabinet and the Emperor with its customary unanimous decision. Army Chief of Staff Gen. Umezo Yoshijir, Navy Chief of Staff Adm. Toyoda Soemu, and War Minister Gen. Anami Korechika maintained that any surrender agreement had to guarantee the Emperor's continued power as sovereign ruler, prevent occupation of major cities such as Tokyo, and place responsibility for disarmament and dealing with war criminals in Japan's own hands. The trio opposing them (Premier Suzuki Kantar, Foreign Minister Tg Shigenori, and Navy Minister Adm. Yonai Mitsumasa) viewed the Potsdam agreement as an ultimatum. In their view, the only negotiable ambiguity was the official position of the Emperor—the Potsdam agreement had applied the term "unconditional surrender" exclusively to the enemy's armed forces....

The spreading awareness of the destructive power released at Hiroshima and Nagasaki increased the urgent atmosphere at these meetings in Tokyo. Nonetheless, it took an unprecedented action by the Emperor, and the extraordinary effort of OWI to publicize his action, to break the Japanese military-civilian deadlock.

Half an hour after the 9 August Cabinet meeting ended, Premier Suzuki Kantaro and Foreign Minister Tg Shigenori called members of the Cabinet and the Supreme Council, and Baron Kiichiro Hiranuma, President of Japan's Privy Council, into an Imperial Conference. For several hours in a hot, airless bomb shelter, the Emperor listened to the opposing arguments. His political role usually consisted of passively endorsing Cabinet decisions. But at 2:00 a.m. on the morning of 10 August, in a deeply moving speech, Japan's Emperor Hirohito called upon the power of his moral and spiritual leadership and directed that Japan should accept the terms of the Potsdam agreement.

There are indications that the Emperor had long wished for an end to the war for practical and emotional reasons. Ascending to the throne in 1926 at the age of 25, Hirohito was an intelligent man, a distinguished marine biologist, and a rather quiet, shy individual. He remained in Tokyo throughout the war, witnessing personally the destruction that he knew to be indicative of what was happening to the rest of his country. According to various historians, he found the arguments of the militarists to be self-seeking and born of false pride. No doubt pressure from the civilian members of his Cabinet and other government officials strengthened his resolve to end the devastation.

So it was that on 10 August, at 3:00 a.m., the Cabinet and the Supreme Council complied and voted in reluctant unanimity to accept the Potsdam offer, but with the stipulation that the Emperor remain the sovereign ruler of the country. By 7:00 a.m., the Foreign Minister had dispatched an announcement of the decision to the United States and China through Japan's Minister Shunichi Kase in Switzerland, and to Great Britain and the USSR through Minister Suemasa Okamoto in Sweden. Japanese officials tensely awaited the Allies' response.

Turmoil in Washington

Washington hotly debated Japan's request for modification of the Potsdam accord. Historian Robert Butow details the opposing arguments: one side was convinced that acceding to Japan's proviso would inspire prolonged fighting; the other side held that assuring the Emperor's continued status as head of state would strengthen post-war reformation.¹⁵

In the end, Secretary of State Byrnes prevailed and prepared the Allied nations' reply, stipulating that the Emperor could remain as a sovereign ruler, but that "from the moment of surrender, the authority of the Emperor and the Japanese Government to rule the state shall be subject to the Supreme Commander of the Allied powers." With the concurrence of the United Kingdom, China, Australia and, ultimately, the USSR, the reply was forwarded to Japan through Switzerland.¹⁶

Getting the Word Out

OWI now played its most dramatic role.

Technically, Japan had not yet surrendered. The war was not yet over. President Truman had ordered the continuation of Allied bombing runs over Japanese military installations. The

people of Japan knew nothing of their government's plan to surrender. Radio Tokyo still exhorted all Japanese to prepare defenses against an enemy invasion.

In a race to save the lives of soldiers still fighting, the Allies' acceptance of Japan's modification of the Potsdam surrender terms was radioed to OWI in Honolulu and Saipan at the same time that it was forwarded to Switzerland. The US War Department sent an urgent dispatch ordering OWI to inform the Japanese people directly, by leaflet and radio, that their government had offered to surrender and that the Allies had accepted the offer. The order, which originated from the White House, threw OWI personnel into high gear. The text for the message was prepared in Washington and dictated by telephone to Honolulu, where it was transcribed, translated into Japanese, lettered, and transmitted to Saipan by "radiophoto" within two hours.

The 17 members of the OWI staff on Saipan were challenged to a previously unmatched degree. By mid-night on 11 August, less than 48 hours after Japan's message was received in Washington, three-quarters of a million leaflets giving notification of the surrender offer had been printed on OWI's three Webendorfer highspeed presses running continually. By the next afternoon, production of OWI leaflet #2117 totaled well over 5 million copies....

On 12 August, aircraft runs departed Saipan at 1:30, 4:30, 7:30 and 11:30 p.m., delivering to the people of Japan the news of their government's surrender offer. The 4" x 5" leaflets rained down by the millions, telling the Japanese people:

These American planes are not dropping bombs on you today. American planes are dropping these leaflets instead because the Japanese Government has offered to surrender, and every Japanese has a right to know the terms of that offer and the reply made to it by the United States Government on behalf of itself, the British, the Chinese, and the Russians. Your government now has a chance to end the war immediately. You will see how the war can be ended by reading the two following official statements.

Two paragraphs then gave the Japanese surrender offer verbatim and the Byrnes response indicating the Allies' willingness to accept that offer. OWI repeated the same message continuously over station KSAI.

The significance of this information barrage cannot be overstated. For the first time the Japanese people became aware that their government was trying to surrender. And it was the first that Japanese officials knew of the Allies' acceptance of their surrender offer, because the OWI notification preceded, by about 72 hours, the receipt of the official diplomatic reply sent through Switzerland.

The Emperor's Next Steps

Copies of the leaflet that fell on the palace grounds were immediately taken to the Emperor by Marquis Kichi Kido, Lord Keeper of the Privy Seal. The Emperor realized that Japanese civilians now knew of the surrender attempt and, more significantly, so did ordinary Japanese soldiers, sailors, and airmen.

Fearing a military coup to ensure continuation of the war, the Emperor decided to take additional action to bring the conflict to an end. On 13 August, when the Cabinet was called into immediate session, members Anami Korechika, Umezo Yoshijir, and Toyoda Soemu unexpectedly dissented anew, saying that an item in the original Potsdam proposal stipulating that postwar Japan would ultimately be governed by the will of the people was against Japanese tradition and therefore compliance was impossible. This reversal precipitated another Imperial Conference at which the Emperor stopped all argument by forcefully declaring that Japan would

accept the Potsdam conditions as modified in the 11 August message from US Secretary of State Byrnes on behalf of the Allied nations.

In an action without precedent, the Emperor decided to issue an Imperial Rescript announcing the capitulation, to be delivered both to the Allies through diplomatic channels and to his subjects in his own voice via radio broadcast. The enormity of this decision must be understood in context: the Emperor was considered a deity—no one was allowed to look upon him from above, few citizens had seen him at all, and the Japanese people had never before heard his voice. Hirohito well understood the powerful effect his broadcast would have.

On 14 August, the Emperor made two recordings of the Rescript for broadcast the next day. Aware that such a powerful communication would doom efforts to continue the war, the military sent soldiers from a Tokyo garrison to attack the Imperial Palace at night, imprison the Emperor, and seize the recordings. They failed to turn up the recordings, however, which had been secured at the radio station. Later that night, War Minister Anami Korechika, having failed to promote his views and control his soldiers, committed suicide, the first of many such actions in the days that followed.

The Surrender Announcement

At noon on 15 August, a stunned population listened to Emperor Hirohito's high, shaking, unfamiliar voice announcing the final surrender of the Japanese nation.

The world was jubilant. In New York, Times Square erupted in a sea of celebrating humanity. In Naples, a USO Andrews Sisters show was completely disrupted as the war-weary soldiers, about to embark from Europe for the Pacific, heard the announcement and realized that their trip would be cancelled. In a prison camp near Tokyo, an American, expecting yet another beating, was handed a paper cup of sake wine and his smiling captor informed him that the war was over.

On Saipan, OWI staff members had little time to savor the moment. They were already hard at work producing leaflets of instruction for the surrendering Japanese on the homeland islands and subsequently in Manchuria, China, New Guinea, and the Philippines.

Washington's Gratitude

Secretary of State Byrnes lost no time in thanking the OWI staff in Honolulu and Saipan. A dispatch from Washington dated 17 August 1945, sent through OWI's Bradford Smith in Honolulu, reads:

"I have been requested by Secretary Byrnes to send appreciation to everyone concerned for the magnificent work done in lettering, translating, printing, sending, and distributing the important leaflet directly before the surrender of Japan. It is the belief of Secretary Byrnes as well as we in this office that the factor which helped to bring about the final surrender was this leaflet...."

On 2 September, formal instruments of surrender were signed by Japanese officials on behalf of the Emperor and by Allied officials on behalf of the governments of the United States, the Republic of China, the United Kingdom, the Union of Soviet Socialist Republics, the Commonwealth of Australia, the Dominion of New Zealand, the Dominion of Canada, the Provisional Government of the French Republic, and the Kingdom of the Netherlands.

Although OWI continued to handle its national affairs through its headquarters in Washington until 12 March 1946, its overseas operations began to wind down after Japan's surrender. On 7 September 1945, oversight of the forward area on Saipan was transferred to the United States Information Service; OWI's Honolulu office closed on 31 October 1945. Chief of

the Forward Area, Richard Hubert, returning to Washington, reflected the sentiment of many on his staff:

It is an honor and privilege to have served with the Office of War Information, which agency deserves more credit than public opinion may ever realize. Operating abroad in secrecy, it is undoubtedly so that the Axis know more about the OWI operations than our own citizens.

These words rang true for years, but finally the story of OWI's important role in the final days of the war in the Pacific can be told.

APPENDIX IV

What would happen if an 800-kiloton nuclear warhead detonated above midtown Manhattan?

Steven Starr, Lynn Eden, Theodore A. Postol
Bulletin of the Atomic Scientists, February 25, 2015

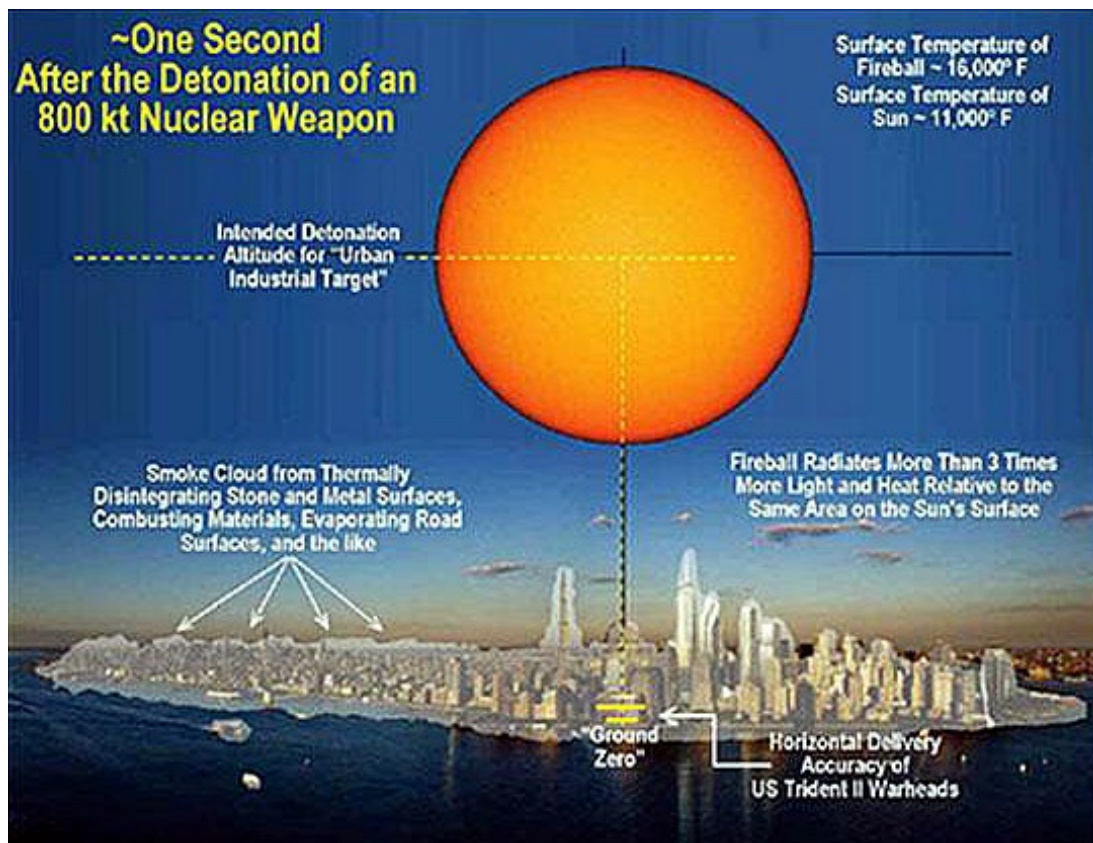

Figure A1. Fireball from detonation of an 800 kT of TNT equivalent device over an Urban- Industrial target. Source: Bulletin of the Atomic Scientists.

Russian intercontinental ballistic missiles are believed to carry a total of approximately 1,000 strategic nuclear warheads that can hit the US less than 30 minutes after being launched. Of this total, about 700 warheads are rated at 800 kilotons; that is,

each has the explosive power of 800,000 tons of TNT. What follows is a description of the consequences of the detonation of a single such warhead over midtown Manhattan, in the heart of New York City.

The initial fireball.

The warhead would probably be detonated slightly more than a mile above the city, to maximize the damage created by its blast wave. Within a few tenths of millionths of a second after detonation, the center of the warhead would reach a temperature of roughly 200 million degrees Fahrenheit (about 100 million degrees Celsius), or about four to five times the temperature at the center of the sun.

A ball of superheated air would form, initially expanding outward at millions of miles per hour. It would act like a fast-moving piston on the surrounding air, compressing it at the edge of the fireball and creating a shockwave of vast size and power. After one second, the fireball would be roughly a mile in diameter. It would have cooled from its initial temperature of many millions of degrees to about 16,000 degrees Fahrenheit, roughly 4,000 degrees hotter than the surface of the sun.

On a clear day with average weather conditions, the enormous heat and light from the fireball would almost instantly ignite fires over a total area of about 100 square miles.

Hurricane of fire.

Within seconds after the detonation, fires set within a few miles of the fireball would burn violently. These fires would force gigantic masses of heated air to rise, drawing cooler air from surrounding areas toward the center of the fire zone from all directions.

As the massive winds drove flames into areas where fires had not yet fully developed, the fires set by the detonation would begin to merge. Within tens of minutes of the detonation, fires from near and far would join to form a single, gigantic fire. The energy released by this mass fire would be 15 to 50 times greater than the energy produced by the nuclear detonation.

The mass fire, or firestorm, would quickly increase in intensity, heating enormous volumes of air that would rise at speeds approaching 300 miles per hour. This chimney effect would pull cool air from outside the fire zone towards the center of the fire at speeds of hundreds of miles per hour. These superheated ground winds of more than hurricane force would further intensify the fire. At the edge of the fire zone, the winds would be powerful enough to uproot trees three feet in diameter and suck people from outside the fire into it.

The intruding winds would drive the flames from burning buildings horizontally along the ground, filling city streets with flames and firebrands, breaking in doors and windows, and causing the fire to jump, sometimes hundreds of feet, swallowing anything not already violently combusting.

These above-hurricane-force ground winds would have average air temperatures well above the boiling point of water. The targeted area would be transformed into a huge hurricane of fire, producing a lethal environment throughout the entire fire zone.

Ground zero: Midtown Manhattan.

The fireball would vaporize the structures directly below it and produce an immense blast wave and high-speed winds, crushing even heavily built concrete structures within a couple miles of ground zero. The blast would tear apart high-rise buildings and expose their contents to the solar temperatures; it would spread fires by exposing ignitable surfaces, releasing flammable materials, and dispersing burning materials.

At the Empire State Building, Grand Central Station, the Chrysler Building, and St. Patrick's Cathedral, about one half to three quarters of a mile from ground zero, light from the fireball would melt asphalt in the streets, burn paint off walls, and melt metal surfaces within a half second of the detonation. Roughly one second later, the blast wave and 750-mile-per-hour winds would arrive, flattening buildings and tossing burning cars into the air like leaves in a windstorm. Throughout Midtown, the interiors of vehicles and buildings in line of sight of the fireball would explode into flames.

Slightly more than a mile from ground zero are the neighborhoods of Chelsea, Midtown East, and Lenox Hill, as well as the United Nations; at this distance, for a split second the fireball would shine 10,000 times brighter than a desert sun at noon. All combustible materials illuminated by the fireball would spew fire and black smoke.

Grass, vegetation, and leaves on trees would explode into flames; the surface of the ground would explode into superheated dust. Any flammable material inside buildings (paper, curtains, upholstery) that was directly exposed to the fireball would burst into flame. The surfaces of the bronze statues in front of the UN would melt; marble surfaces exposed to the fireball would crack, pop, and possibly evaporate.

At this distance from the fireball, it would take about four seconds for the blast wave to arrive. As it passed over, the blast wave would engulf all structures and crush them; it would generate ferocious winds of 400 to 500 miles per hour that would persist for a few seconds.

The high winds would tear structural elements from buildings and cause them to disintegrate explosively into smaller pieces. Some of these pieces would become destructive projectiles, causing further damage. The superheated, dust-laden winds would be strong enough to overturn trucks and buses.

Two miles from ground zero, the Metropolitan Museum of Art, with all its magnificent historical treasures, would be obliterated. Two and half miles from ground zero, in Lower Manhattan, the East Village, and Stuyvesant Town, the fireball would appear 2,700 times brighter than a desert sun at noon. There, thermal radiation would melt and warp aluminum surfaces, ignite the tires of autos, and turn exposed skin to charcoal, before the blast wave arrived and ripped apart the buildings.

Three to nine miles from ground zero.

Midtown is bordered by the relatively wide Hudson and East rivers, and fires would start simultaneously in large areas on both sides of these waterways (that is, in Queens and Brooklyn as well as Jersey City and West New York). Although the direction of the fiery winds in regions near the river would be modified by the water, the overall wind pattern from these huge neighboring fire zones would be similar to that of a single mass fire, with its center at Midtown, Manhattan.

Three miles from ground zero, in Union City, New Jersey, and Astoria, Queens, the fireball would be as bright as 1,900 suns and deliver more than five times the thermal energy deposited at the perimeter of the mass fire at Hiroshima. In Greenpoint, Brooklyn, and in the Civic Center of Lower Manhattan, clothes worn by people in the direct line of sight of the fireball would burst into flames or melt, and uncovered skin would be charred, causing third-degree and fourth-degree burns.

It would take 12 to 14 seconds for the blast wave to travel three miles after the fireball's initial flash of light. At this distance, the blast wave would last for about three seconds and be accompanied by winds of 200 to 300 miles per hour. Residential structures would be destroyed; high-rises would be at least heavily damaged.

Fires would rage everywhere within five miles of ground zero. At a distance of 5.35 miles from the detonation, the light flash from the fireball would deliver twice the thermal energy experienced at the edge of the mass fire at Hiroshima. In Jersey City and Cliffside Park, and in Woodside in Queens, on Governors Island and in Harlem, the light and heat to surfaces would approximate that created by 600 desert suns at noon.

Wind speed at this distance would be 70 to 100 miles per hour. Buildings of heavy construction would suffer little structural damage, but all exterior windows would be shattered, and non-supporting interior walls and doors would be severely damaged or blown down. Black smoke would effuse from wood houses as paint burned off surfaces and furnishings ignited.

Six to seven miles from ground zero, from Moonachie, New Jersey, to Crown Heights, Brooklyn, from Yankee Stadium to Corona, Queens and Crown Heights, Brooklyn, the fireball would appear 300 times brighter than the desert sun at noon. Anyone in the direct light of the fireball would suffer third degree burns to their exposed skin. The firestorm could engulf neighborhoods as far as seven miles away from ground zero, since these outlying areas would receive the same amount of heat as did the areas at the edge of the mass fire at Hiroshima.

Nine miles from ground zero, in Hackensack, Bayonne, and Englewood, New Jersey, as well as in Richmond Hill, Queens, and Flatlands, Brooklyn, the fireball would be about 100 times brighter than the sun, bright enough to cause first- and second-degree burns to those in line of sight. About 36 seconds after the fireball, the shockwave would arrive and knock out all the windows, along with many interior building walls and some doors.

No survivors.

Within tens of minutes, everything within approximately five to seven miles of Midtown Manhattan would be engulfed by a gigantic firestorm. The fire zone would cover a total area of 90 to 152 square miles (230 to 389 square kilometers). The firestorm would rage for three to six hours. Air temperatures in the fire zone would likely average 400 to 500 degrees Fahrenheit (200 to 260 Celsius).

After the fire burned out, the street pavement would be so hot that even tracked vehicles could not pass over it for days. Buried, unburned material from collapsed buildings throughout the fire zone could burst into flames when exposed to air—months after the firestorm had ended.

Those who tried to escape through the streets would have been incinerated by the hurricane-force winds filled with firebrands and flames. Even those able to find shelter in the lower-level sub-basements of massive buildings would likely suffocate from fire-generated gases or be cooked alive as their shelters heated to oven-like conditions.

The fire would extinguish all life and destroy almost everything else. Tens of miles downwind of the area of immediate destruction, radioactive fallout would begin to arrive within a few hours of the detonation.

But that is another story.

Note: The Electro Magnetic Pulse (EMP) from an initial attack on NATO nations would probably disable most of the local counter force electronics. A response would result from the 14 USA Ohio class and 4 UK navy Vanguard trident class submarines and French 3 ballistic missiles submarines. The Tsar Bomba, code-named "Ivan", that was detonated by Russia in 1961 in the Arctic Ocean was 50 MT, or more than 50 times greater than 800 kT. In its original construction the Tsar Bomba was capable of releasing 100 MT. The yield was decreased as the plane dropping it would not have time to get away from the blast wave. At 50 MT the plane had to descend at 25 miles away from the explosion or it would be destroyed by the blast wave. The explosion was used to encourage the USA to agree to the test ban treaty.